



# SPIRIT CR900ENT Fitness Bike Owner's Manual

[Home](#) » [SPIRIT](#) » SPIRIT CR900ENT Fitness Bike Owner's Manual 

## Contents

- [1 SPIRIT CR900ENT Fitness Bike](#)
- [2 Product Usage Instructions](#)
- [3 IMPORTANT SAFETY INSTRUCTIONS](#)
- [4 UNPACKING](#)
- [5 OVERVIEW](#)
- [6 MAINTENANCE MENU](#)
- [7 ETHERNET SETUP](#)
- [8 TOUCH SCREEN OPERATION](#)
- [9 DISPLAY OPTIONS](#)
- [10 FIT TEST PROGRAM](#)
- [11 Documents / Resources](#)
  - [11.1 References](#)
- [12 Related Posts](#)



**SPIRIT CR900ENT Fitness Bike**



## Product Information

The CR900ENT Fitness Bike is a high-quality product from Spirit Fitness. It is designed for indoor use only and should not be exposed to rain or moisture. The bike has an operating temperature specification of 40 to 120 degrees Fahrenheit and a humidity of 95% non-condensing. The product comes with a manufacturer's limited warranty.

The bike features a touchscreen console that allows you to select from various programs and monitor your workout progress. It also has cup holders, a seat cushion, and quality pedals for your comfort during use. The assembly instructions are provided in the user manual and should be followed carefully to ensure proper setup and usage.

## Product Usage Instructions

1. Before using the CR900ENT Fitness Bike, read and understand all instructions in the user manual.
2. Record the name of the dealer, their telephone number, and the date of purchase in the space provided on page 2 of the user manual.
3. Register your purchase by completing the self-addressed product registration card or online through the Spirit Fitness website.
4. Ensure that the bike is set up according to the assembly instructions provided in the user manual.
5. Wear quality athletic shoes during use to avoid leg fatigue.
6. Use the touchscreen console to select from various programs and monitor your workout progress.
7. Do not attempt any customizing, adjustments, repair, or maintenance that is not described in the user manual.
8. After each use, wipe down the bike with a clean, damp cloth and ensure that it is properly stored in a dry, cool place.
9. Refer to the user manual for general maintenance instructions and contact Spirit Fitness for any needed support or warranty information.

Following these product usage instructions will help you to safely and effectively use your CR900ENT Fitness Bike for a satisfying workout experience.

Thank you for purchasing our product, please save these instructions. Please do not perform or attempt any customizing, adjustments, repair or maintenance that is not described in this manual

Congratulations on your new fitness bike and welcome to the Spirit Fitness family!

Thank you for your purchase of this quality fitness bike from Spirit Fitness. Your new fitness bike was manufactured by one of the leading fitness manufacturers in the world and is backed by one of the most comprehensive warranties available. Through your dealer, Spirit Fitness will do all we can to make your ownership experience as pleasant as possible for many years to come. If not purchased directly from Spirit Fitness, the local dealership where you purchased this fitness bike is your administrator for all Spirit Fitness warranty and service needs. Their responsibility is to provide you with the technical knowledge and service personnel to make your experience more informed and any difficulties easier to remedy.

Please take a moment at this time to record the name of the dealer, their telephone number, and the date of purchase below to make any future, needed contact easy. We appreciate your support and we will always remember that you are the reason that we are in business.

Yours in Health, Spirit Fitness

- NAME OF DEALER \_\_\_\_\_
- DEALER PHONE # \_\_\_\_\_
- PURCHASE DATE \_\_\_\_\_

## **IMPORTANT SAFETY INSTRUCTIONS**

### **WARNING**

- Before beginning this or any exercise program, consult a physician. This is especially important for persons over the age of 35 or persons with pre-existing health conditions.
- Keep children away from the fitness bike. There are obvious pinch points and other caution areas that can cause harm.
- Keep hands away from all moving parts.
- Never drop or insert any object into any openings.
- Do not use outdoors.
- Do not attempt to use your fitness bike for any purpose other than for the purpose it is intended.
- The hand pulse sensors are not medical devices. Various factors, including the user's movement, may affect the accuracy of heart rate readings. The pulse sensors are intended only as exercise aids in determining heart rate trends in general.
- Wear proper shoes. High heels, dress shoes, sandals or bare feet are not suitable for use on your fitness bike. Quality athletic shoes are recommended to avoid leg fatigue.
- Maximum User Weight: 450 lbs
- This appliance is not intended for use by persons with reduced physical, sensory or mental capabilities, or lack of experience and knowledge, unless they have been given supervision or instruction concerning use of the appliance by a person responsible for their safety.
- Keep children under the age of 13 away from this machine.

SAVE THESE INSTRUCTIONS – THINK SAFETY!

## **IMPORTANT ELECTRICAL INSTRUCTIONS**

### **WARNING**

NEVER expose this fitness bike to rain or moisture. This product is NOT designed for use outdoors, near a pool or spa, or in any other high humidity environment. The operating temperature specification is 40 to 120 degrees Fahrenheit, and humidity is 95% non-condensing (no water drops forming on surfaces).

## **IMPORTANT OPERATION INSTRUCTIONS**

- NEVER operate this fitness bike without reading and completely understanding the results of any operational change you request from the computer console.
- Understand that changes in resistance do not occur immediately. Set your desired resistance level on the computer console and release the adjustment button. The computer will obey the command gradually.
- Use caution while participating in other activities while pedaling on your fitness bike; such as watching television, reading, etc. These distractions may cause you to lose
- which may result in serious injury.
- Do not use excessive pressure on console control buttons. They are precision set to function properly with little finger pressure.

## **WARNING**

This product can expose you to chemicals including Toluene and Acrylamide which are known to the State of California to cause Cancer and birth defects or other reproductive harm. For more information, go to [www.P65Warnings.ca.gov](http://www.P65Warnings.ca.gov)

## **RECORD YOUR SERIAL NUMBER**

Please record the serial number of this fitness product in the space provided below. The serial number is located at the front of the fitness bike.

- SERIAL NUMBER:

## **REGISTER YOUR PURCHASE**

The self-addressed product registration card must be completed in full and returned to Spirit Fitness. You can also go to [www.spiritfitness.com/warranty](http://www.spiritfitness.com/warranty) under the Support tab to register online.

## **UNPACKING**

1. Cut the straps, then along the dotted line on the bottom of the box; lift the box over the unit and unpack.
2. Locate the hardware package. The hardware is separated into four steps. Remove the tools first. Remove the hardware for each step as needed to avoid confusion. The numbers in the instructions that are in parenthesis (#) are the item number from the assembly drawing for reference.

## **TOOLS INCLUDED:**

- 13/15mm Wrench
- 17mm Wrench (2)
- Phillips Screwdriver
- 5mm Allen Wrench
- 6mm Allen Wrench

## **PARTS INCLUDED:**

- 1 Main Frame
- 1 Console Mast
- 1 Rear Stabilizer
- 1 Seat Back Frame
- 1 Front Handle Bar
- 1 Rear Handle Bar
- 1 Seat Back Cover
- 2 Console Mast Covers
- 1 Console Bracket Cover
- 2 Rear Stabilizer Covers
- 1 Console
- 1 Seat Cushion
- 2 Cup Holders
- 1 Rear Handle Bar Cover
- 2 Pedals
- 1 Hardware Kit
- 1 Seat Cover Retaining Bracket

## **STEP ONE**

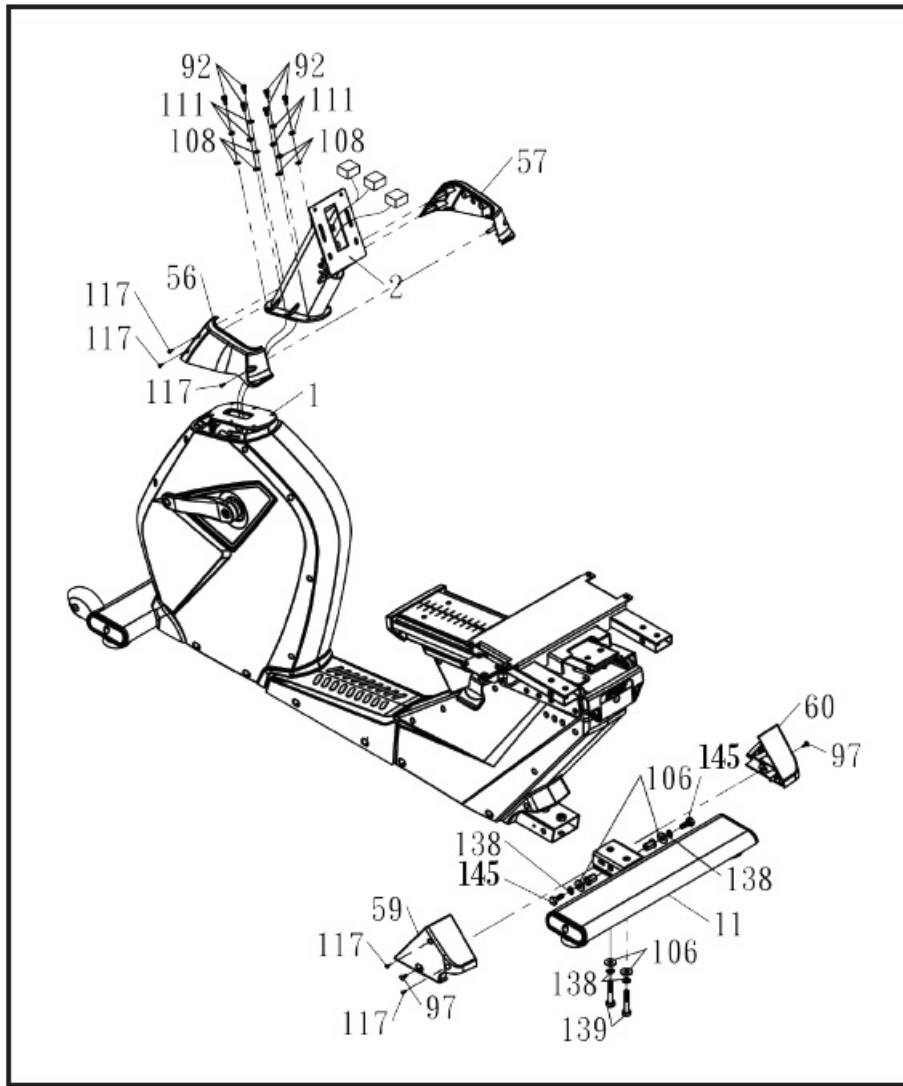

### HARDWARE FOR STEP 1

PART	TYPE	DESCRIPTION	QTY
92	BOLT	M6x1.0x12mm	6
97	SCREW	M5x0.8x12mm	2
106	WASHER	10x25x2.0	4
108	WASHER	6x13x1.0	6
111	SPLIT WASHER	6	6
117	SCREW	3.5x12mm	5
138	SPLIT WASHER	10x1.5	4
139	BOLT	M10x1.5x55mm	2
145	BOLT	M10x1.5x30mm	2

1. Install REAR STABILIZER (11) onto MAIN FRAME (1) with 2 short BOLTS (145), 2 long BOLTS (139), 4 SPLIT WASHERS (138), and 4 WASHERS (106).
2. Attach left and right STABILIZER COVERS (59 & 60) to MAIN FRAME (1) with 2 SCREWS (97). Join together with 2 SELF TAPPING SCREWS (117).

3. Run the WIRING HARNESS through the CONSOLE MAST (2) and out the top.
4. Attach CONSOLE MAST (2) to MAIN FRAME (1) using 6 BOLTS (92), 6 SPLIT WASHERS (111), and 6 WASHERS (108).
5. Place left and right CONSOLE MAST COVERS (56 & 57) around base of CONSOLE MAST (2). Join covers together with 3 SELF TAPPING SCREWS (117).

## STEP TWO

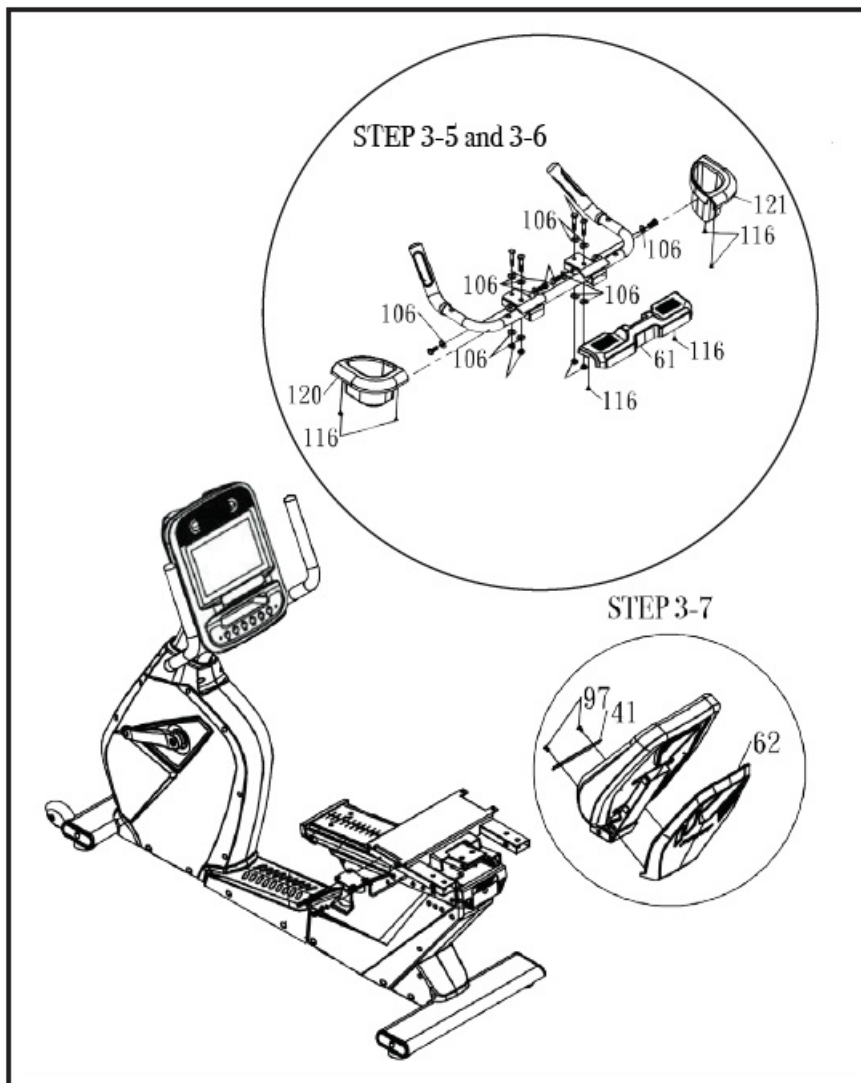

HARDWARE FOR STEP 2			
PART	TYPE	DESCRIPTION	QTY
94	BOLT	M8x1.25x25mm	2
97	SCREW	M5x0.8x12mm	8
105	WASHER	8x18x1.5	2
112	SPLIT WASHER	8x1.5	2

1. Attach FRONT HANDLE BAR (8) to CONSOLE MAST (2) with 2 BOLTS (94), 2 SPLIT WASHERS (112) and 2 WASHERS (105).
2. Connect WIRING HARNESS CABLES (74, 131) to CONSOLE (68).
3. Connect WIRING HARNESS CABLES (74, 127, 128, 129, 131, 132, 137) to CONSOLE (68). Attach CONSOLE

- (68) to CONSOLE MAST (2) with 4 SCREWS (97). Ensure all cables do not become pinched.
4. Attach CONSOLE BRACKET COVER (64) to CONSOLE MAST (2) using 4 SCREWS (97).

### STEP THREE

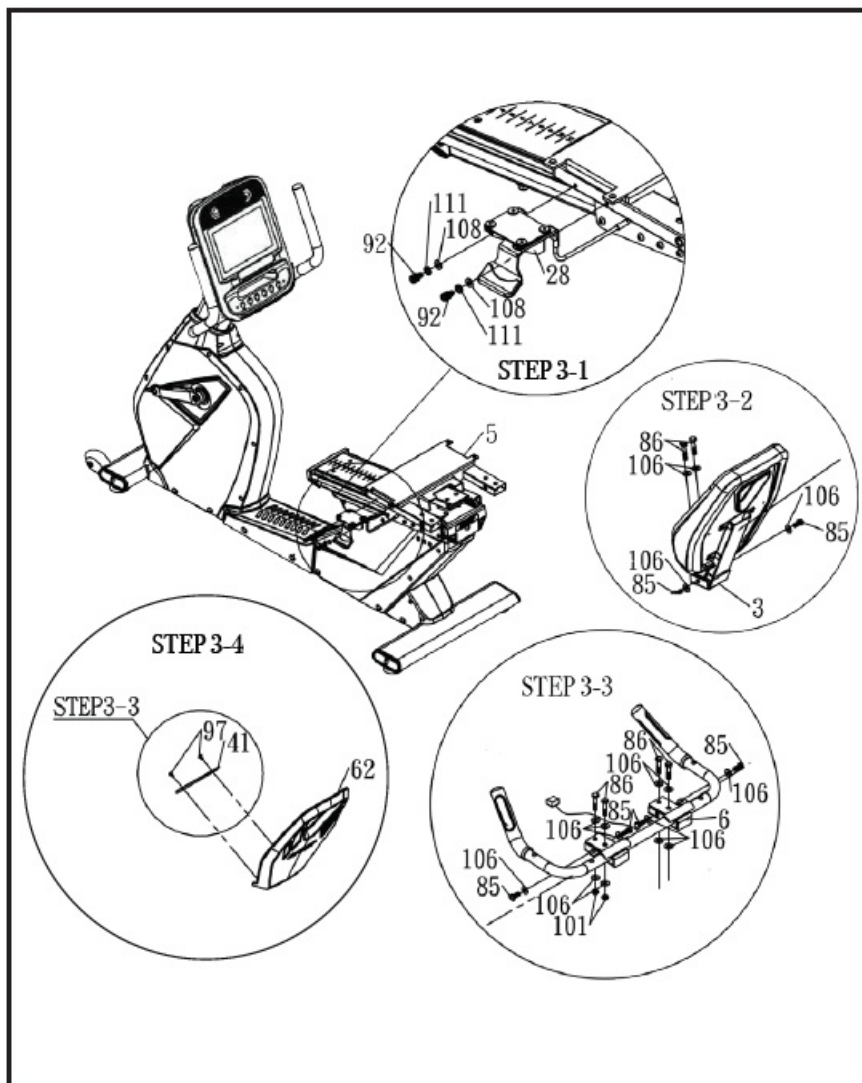

HARDWARE FOR STEP 3			
PART	TYPE	DESCRIPTION	QTY
85	BOLT	M10x1.5x25mm	6
86	BOLT	M10x1.5x50mm	6
92	BOLT	M6x1.0x12mm	2
101	NUT	M10xP1.5x8	4
106	WASHER	10x25x2.0	16
108	WASHER	6x13x1.0	2
111	SPLIT WASHER	6	2
116	SELF-TAPPING SCREW	4x12mm	6



1. Install SEAT RELEASE LEVER (28) onto SEAT CARRIAGE FRAME (5) with 2 BOLTS (92), 2 LOCK WASHERS (111), and 2 WASHERS (108).
2. Install SEAT BACK FRAME (3) onto SEAT CARRIAGE FRAME (5) with 2 short BOLTS (85), 2 long BOLTS (86), and 4 WASHERS (106).
3. Attach REAR HANDLE BAR (6) to SEAT CARRIAGE FRAME (5) using 4 long BOLTS (86), 4 short BOLTS (85), 12 WASHERS (106), and 4 NUTS (101). And connect the WIRING HARNESS CABLES between REAR HANDLE BAR (6) and SEAT CARRIAGE FRAME (5).
4. Loosen 2 SCREWS (97) to remove SEAT COVER RETAINING BRACKET (41) from SEAT BACK FRAME (3).
5. Attach REAR HANDLE BAR COVER (61) to REAR HANDLE BAR (6) using 2 SELF TAPPING SCREWS (116).
6. Attach CUP HOLDERS (120 & 121) to REAR HANDLE BAR (6) using 4 SELF TAPPING SCREWS (116).
7. Attach SEAT BACK COVER (62) to SEAT BACK FRAME (3). Install SEAT COVER RETAINING BRACKET (41) using 2 SCREWS (97).

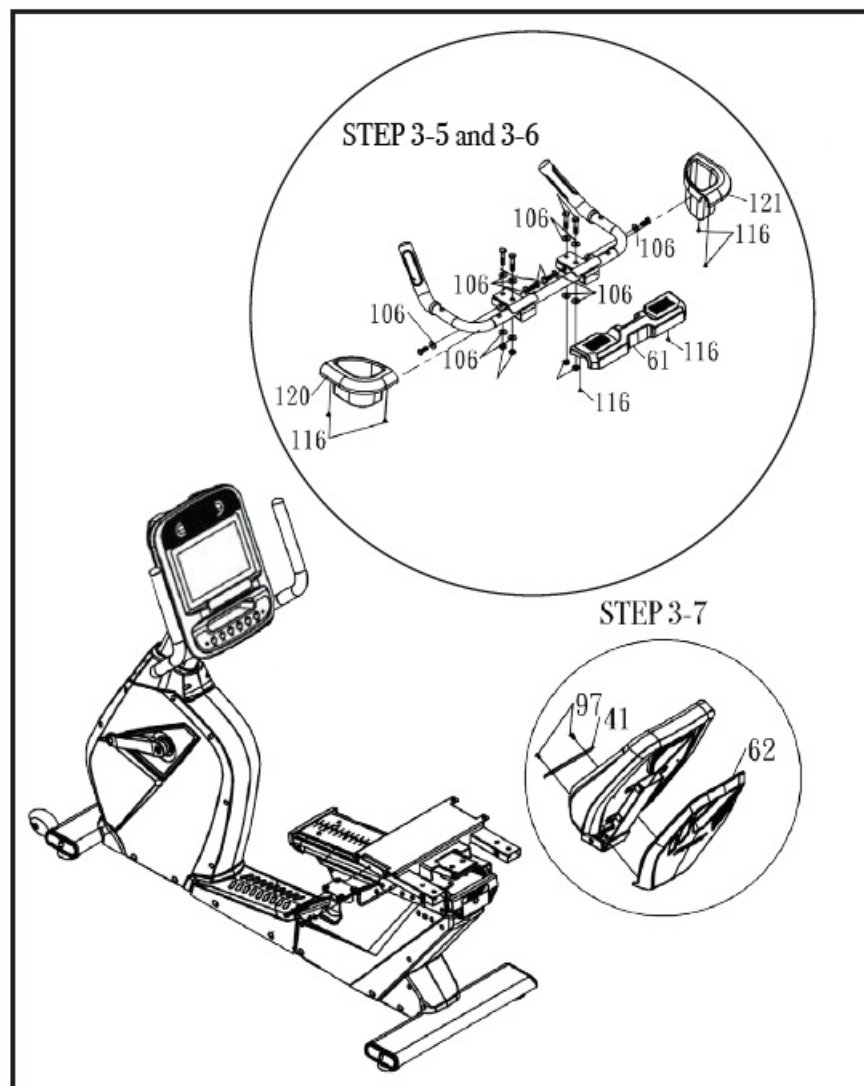

#### STEP FOUR

HARDWARE FOR STEP 4			
PART	TYPE	DESCRIPTION	QTY
85	BOLT	M10x1.5x25mm	6

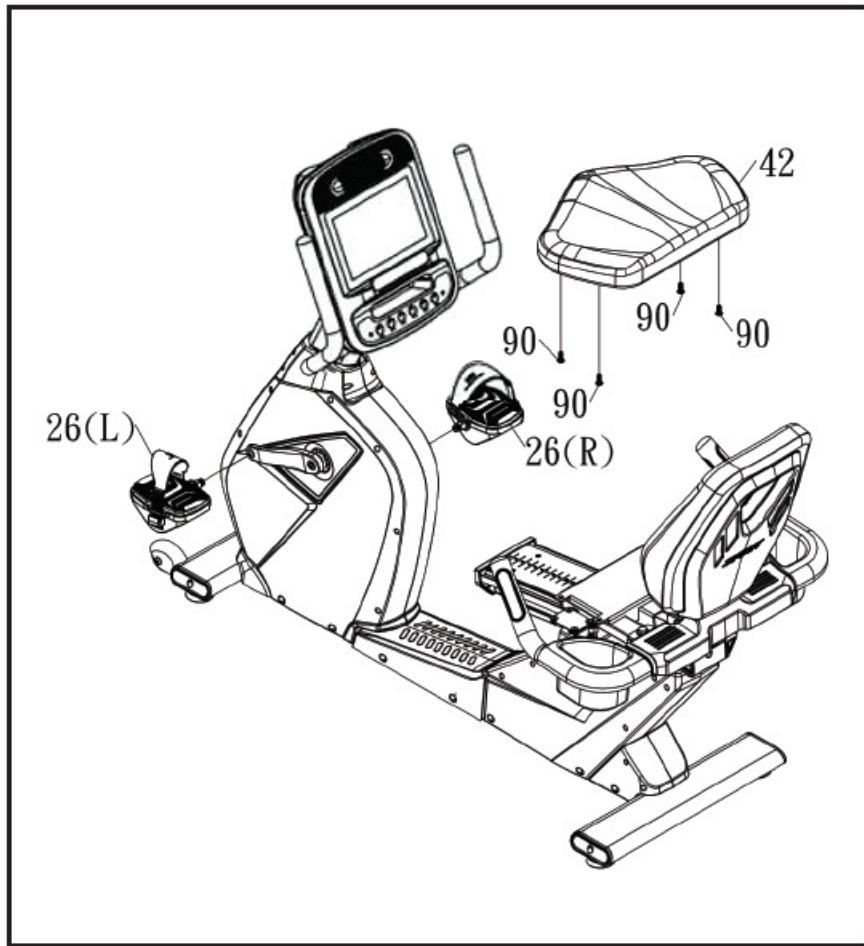

1. Install the PEDALS (26L & 26R) onto the CRANK ARMS (22 & 23). The left pedal has a reverse thread and will be screwed in counterclockwise. Tighten to 300 in-lbs. (34 N•m) of torque.
2. Attach BOTTOM SEAT CUSHION (42) to SEAT CARRIAGE FRAME (5) with 4 BOLTS (85).

## OVERVIEW

Integrated adjustable fan for workout comfort

10.1" touchscreen display with multiple viewing modes

Tablet friendly reading rack holder

Accessory tray for secure placement of keys, smartphones, etc.



## STARTING OPERATION

Plug in the power cord located at the front base of the unit. When the power is turned on, the screen will show the initial image and then enter the Home screen.

- Home screen: Begin operation by touching the icons.

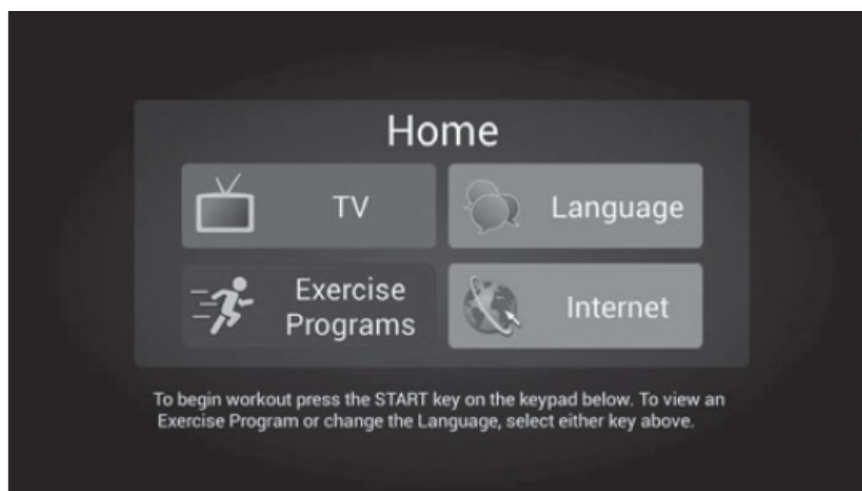

- Quick operating buttons are convenient for basic bike functions.



## SETTINGS

Press the "Home" icon ten consecutive repetitions to enter the Maintenance suite.

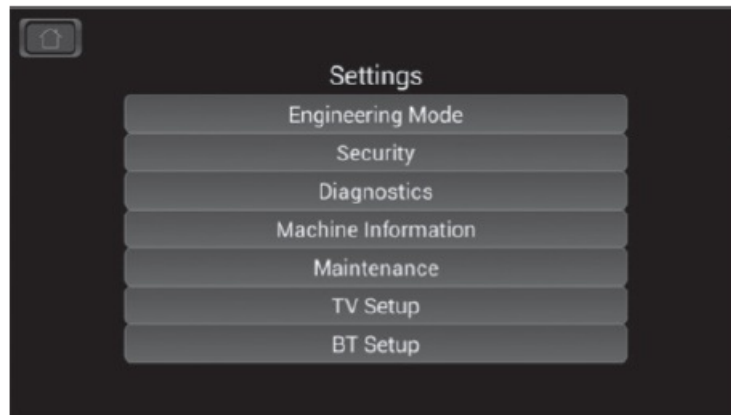
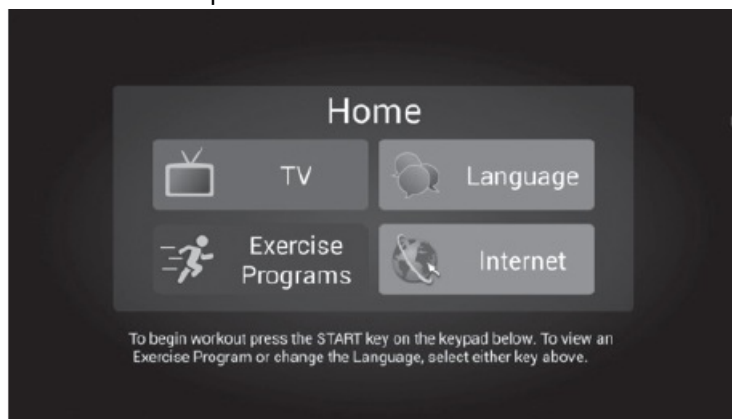

The two most commonly used menus for setting up the exercise machine are described below; the TV Setup and Maintenance menus. For information on other sections of the Maintenance, suite refer to the technical service manual or call Spirit Service.

## TV SETUP



1. Begin by selecting either TV or HDMI as the tuner source.
2. Press OSD Menu. The first highlighted item on the menu is Air/Cable and then Cable or Air afterward. Press the OSD Enter to change the selection between Cable and Air Signal source, usually Cable).
3. After selecting Cable or Air use the arrows located below the OSD Exit button to navigate down to Auto Scan then press OSD Enter. The tuner will now scan for all available channels. Press OSD Exit when done. You can modify the channels by pressing the Update Channel List.
4. The OSD Command button is for engineering use only.

## MAINTENANCE MENU

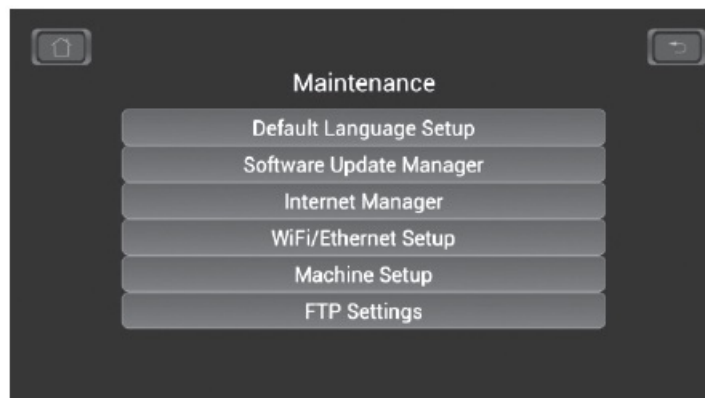

- The Default language setup allows you to select the main language that will be shown when the console is turned on. You are able to select the language in the Home menu, but once the user finishes using the machine the console will return to this default language.
- Software Update Manager is used to install new versions of the application software.
- Internet Manager allows you to modify the internet sites that are shown in the Internet menu.
- Wifi/Ethernet Setup is for selecting a Wifi signal or Ethernet addresses.
- Machine Setup allows you to select whether the Csafe port is used for Csafe or CAB TV Tuner. This menu also allows you to set the screen brightness.
- FTP Settings is the Spirit FTP site address where Error logs and remote troubleshooting can be managed.

## INTERNET MANAGER



1. Remove a link by pressing the icon of the site you want to remove for two seconds. A pop-up window will ask you to confirm the removal.
2. To add a website press the dotted outline box. A pop-up window will ask you to enter the web address and upload a picture for the final button if you wish. You could also just use a default-look button and type in the name of the site, which will then be the button icon.

## WIFI/ETHERNET SETUP

Press the desired button for setting up Wifi or Ethernet.



## WIFI SETUP

Turn Wifi on and press scan for available Wifi connections. Press desired connection and follow the on-screen directions.



## ETHERNET SETUP

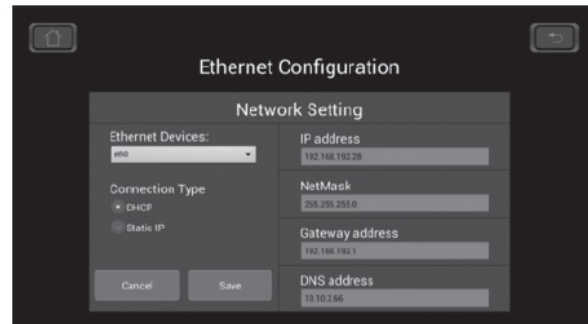
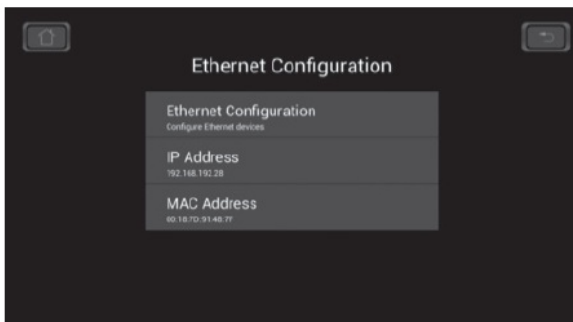

- Press Ethernet Configuration to set up a new connection.
- Select DHCP to search for connection or Static IP to enter manually

## BLUETOOTH PAIRING PROCEDURE

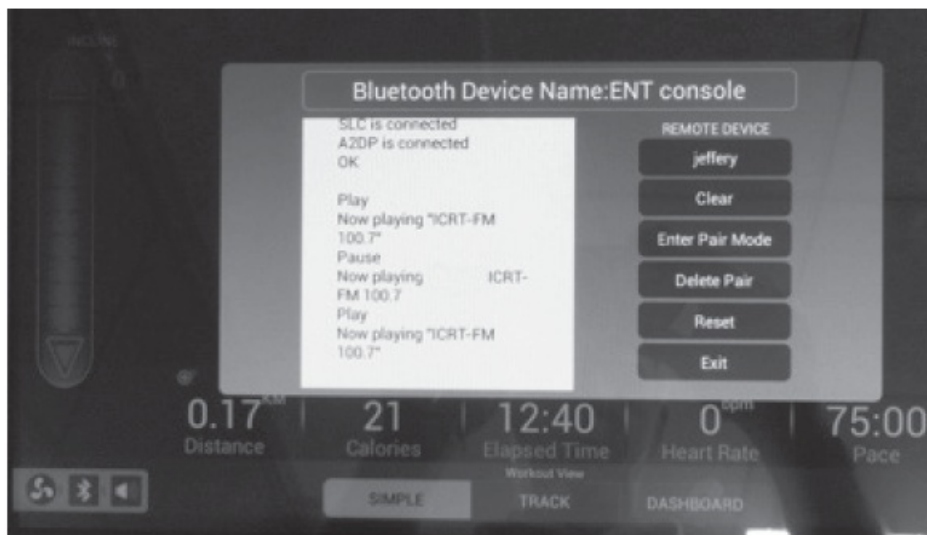

1. Press the Blue Tooth (BT) icon on the bottom left of the screen.
2. The BT pop-up screen will appear. Turn on Phone/tablet BT and then press Pair Mode on ENT Menu.
3. The menu will show Entering Pairing mode and the phone will show A2DP as an available device.
4. The A2DP console and phone will ask you to confirm pairing, press OK.

5. Pairing complete

6. Open audio APP on phone and the audio will be played through the headphone port on the ENT console.

## TOUCH SCREEN OPERATION

### LANGUAGE



When you press the Language button on Home screen, it enters the menu with all language options. There are 12 languages to choose from. Touch the desired language and the system will return to the Home screen which will now be in the chosen language.

### TV



- When the TV button on the Home screen is pressed, it directly enters TV interface.
- Now you can enjoy TV programs. If you want to enjoy TV while exercising, press Start button at front of the bike to initiate Quick Start or press Programs to select a workout.
- You can change the TV channels by pressing the channel up/down buttons on the right side of the screen. You can also use the Volume Up/Down buttons to change the sound levels. If you want to silence the audio touch Mute button. Touch the Max Screen to switch to full screen viewing. Touching anywhere on the screen will return it to the original screen size.



## INTERNET



When the Internet button on the Home page is pressed, you are directed to Internet interface. There are 6 basic internet sites to choose from. You may change or add other sites through the Maintenance program (more on this later in the manual in the System Maintenance Suite section).

**NOTE:** An internet cable connection or WIFI connection is required.

## EXERCISE PROGRAMS

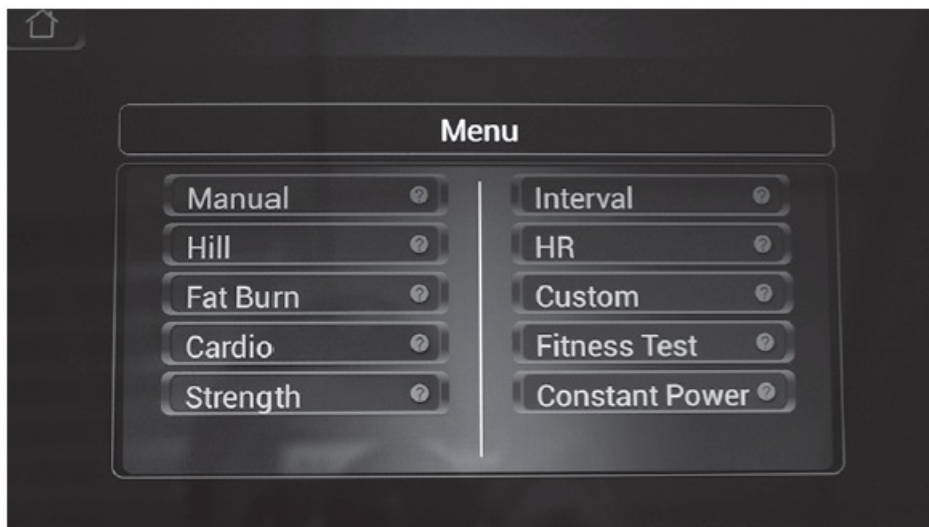

When the Exercise Program button on the Home page is pressed, the fitness program menu appears. There are 12 programs to choose from. Press the desired program button and follow the on-screen directions. For Manual Program as an example, just touch Manual button on the screen to enter the programming for Manual.

## FUNCTIONS OF THIS BIKE

The Touch-control screen is used for operating all functions of the bike. You can directly touch any button on the screen or through quick button on the bottom to control functions. On the lower portion of the console there is the Start button to begin the workout, Stop button to pause/stop programs, Level button to change workload and a Fan button to turn the fan on or off.

## QUICK START

This is the quickest way to start a workout. After the console powers up you just press the Start button to begin. This will initiate the Quick Start mode. In Quick Start the Time will count up from zero, all workout data will start to accrue and the workload may be adjusted manually by pressing the Up and Down buttons. The dot matrix display will show just the bottom row lit. As you increase the workload more rows will light indicating a harder workout. The fitness bike will get harder to pedal as the rows increase. The dot matrix has 24 columns of lights and each column represents 1 minute. At the end of the 24th column (or 24 minutes of work) the display will wrap around and start at the first column again.

There are 40 levels of resistance – displayed as 10 rows of lights – available for plenty of variety. The first 10 levels are very easy workloads, and the changes between levels are set to a good progression for de-conditioned users. Levels 10-20 are more challenging but the increases from one level to the next remain small. Levels 20-30 start getting tough as the levels jump more dramatically. Levels 30-40 are extremely hard and are good for short interval peaks and elite athletic training.

Spirit Fitness

## DISPLAY OPTIONS

### SIMPLE



The default display at the start of a program is a Simple display. The profile window shows the work level graphically. All your workout values are displayed on the bottom of the screen. Some of the data windows have a + sign at the top indicating more data available. Press the data window to see other information available. Below the profile window are buttons that allow you to switch the display between the speed and incline profiles. Below the data displays are Track and Dashboard buttons for selecting other display options. A muscle profile displays active muscle groups as workloads change.

### TRACK



The Track display gives a graphical representation of your position on a virtual track. The image shows the track with a lap counter and other values.

## DASHBOARD



The Dashboard display shows a larger display area of button information.

## STOP BUTTON

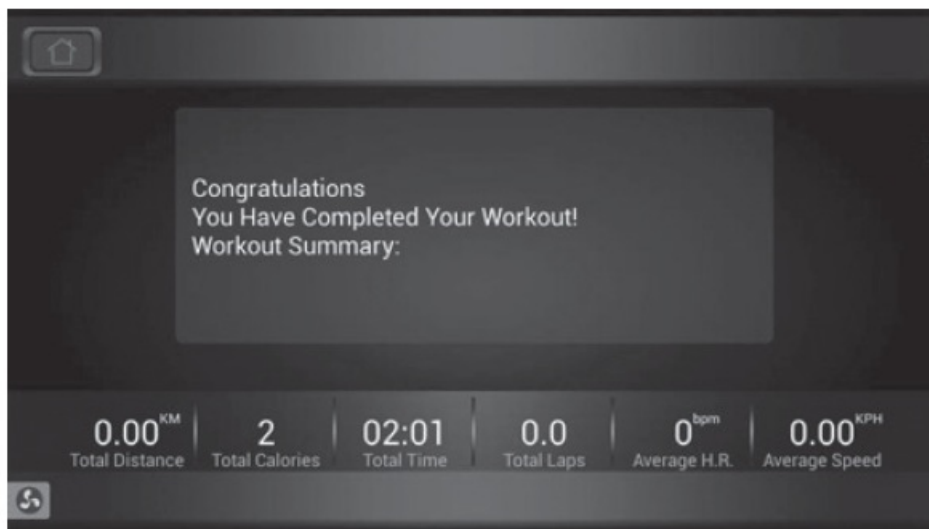

When using the Stop button to end the program, it enters the summary screen.

On the summary screen, all accumulated values concerning the workout are displayed. You can touch the Home button at left top or press Stop button to return to the home screen.

## HEART RATE FEATURE

The Pulse (Heart Rate) on the screen shows the current value of your heart rate in beats per minute. You must use both left and right stainless steel sensors to pick up your pulse. Pulse values are displayed anytime the computer is receiving a Grip Pulse signal. You may use the Grip Pulse feature while in Heart Rate Control. The console will also pick up wireless heart rate transmitters that are 5 khz Polar compatible.

## TO TURN THE BIKE OFF

The screen will automatically turn off (go to sleep) after 30 minutes of inactivity. This function is called sleep mode. In sleep mode, the bike will power down everything except for a minimum of circuitry for detecting button presses, so it will start up again if this is activated. There is only a tiny amount of current used in sleep mode (about the same as your TV when it is turned off) and it is perfectly fine to leave the main power switch on in sleep mode.

[www.spiritfitness.com](http://www.spiritfitness.com)

## PROGRAMMING THE CONSOLE

Each of the programs can be customized with your personal information and changed to suit your needs. Some of the information asked for is necessary to ensure the readouts are correct. You will be asked for your Age and Weight. Entering your Age ensures that the Heart Rate bar graph shows the correct number. Your Age is also necessary during the Heart Rate control program to ensure the correct settings are in the program for your Age. Otherwise the work settings could be too high or low for you; entering your Weight aides in calculating a more correct Calorie reading. Although we cannot provide an exact calorie count we do want to be as close as possible. **CALORIE NOTE:** Calorie readings on every piece of exercise equipment, whether it is in a gym or at home, are not accurate and tend to vary widely. They are meant only as a guide to monitor your progress from workout to workout. The only way to measure your calorie burn accurately is in a clinical setting connected to a host of machines. This is because every person is different and burns calories at a different rate. Some good news is that you will continue to burn calories at an accelerated rate for at least an hour after you have finished exercising!

## ENTERING A PROGRAM & CHANGING SETTINGS

When you enter a program (by pressing a program button then Enter button) you have the option of entering your own personal settings. If you want to work out without entering new settings, then just press the Start button. This will bypass the programming of data and take you directly to the start of your workout. If you want to change the personal settings, then just follow the instructions in the Message Window. If you start a program without changing the settings, the default, or pre-saved settings will be used.

The Spirit Fitness CR900ENT offers ten preset programs: Manual, Hills, Fat Burn, Cardio, Strength, Interval, HR, Custom, Fitness Test, and Constant Power.

1. Select a program then press the Enter button to begin customizing the program with your personal data, or just press the Start button to begin the program with the default settings.
2. After selecting a program and pressing enter to set your personal data, tap the Time window and use key pad adjust the time. After adjusting the time, press Enter. (**NOTE:** You may press Start at any time during the programming to begin with only settings you have modified at that point).
3. The Age window will now be displaying a value indicating your Age. (Entering the correct Age will affect the Heart rate bar graph accuracy and also needed for the HR programs. Use numeric key pads to make adjustments, and then press Enter confirm. Default age is 30 years old. Range=10 to 110).
4. The Weight window will now be showing a value indicating your Bodyweight. (Entering your correct bodyweight

affects the Kcal readout accuracy. Use the numeric key pad to make adjustments, and press the Enter button to confirm. (Default weight is 70KG. Range=10 to 150).

- The Max Level window will now be displaying a value indicating the maximum resistance level the program will reach at its peak. Use numeric key pad to make adjustments, and then press Enter to confirm and continue (Default max Level is 5. Range=5 to 40).
- Now press the Start button to begin your workout.

### MANUAL

The level of resistance is controlled by the user. Increase or decrease levels at any time during your workout.

### HILL

This program follows a triangle or pyramid type of gradual progression from approximately 10% of maximum effort (the level that you chose before starting this program) up to a maximum effort which lasts for 10% of the total workout time, then a gradual regression of resistance back to approximately 10% of maximum effort.

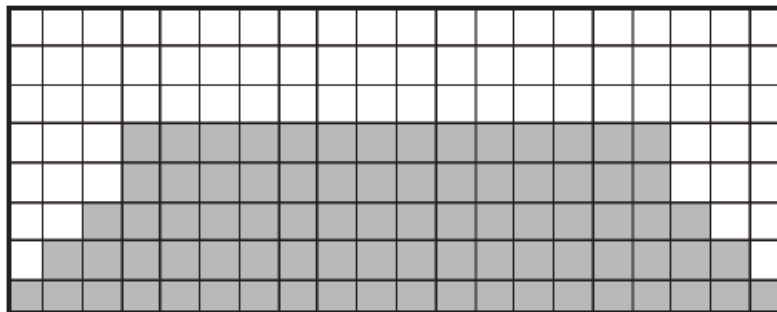
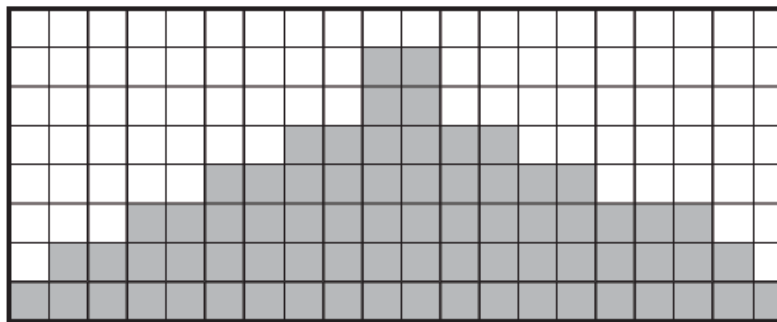

### FAT BURN

This program follows a quick progression up to the maximum resistance level (default or user input level) that is sustained for 2/3 of the workout. This program will challenge your ability to sustain your energy output for an extended period of time.

### CARDIO

This program presents a quick progression up to near maximum resistance level (default or user input level). It has slight fluctuations up and down to allow your heart rate to elevate, and then recover repeatedly, before beginning a quick cool down. This will build up your heart muscle and increase blood flow and lung capacity.

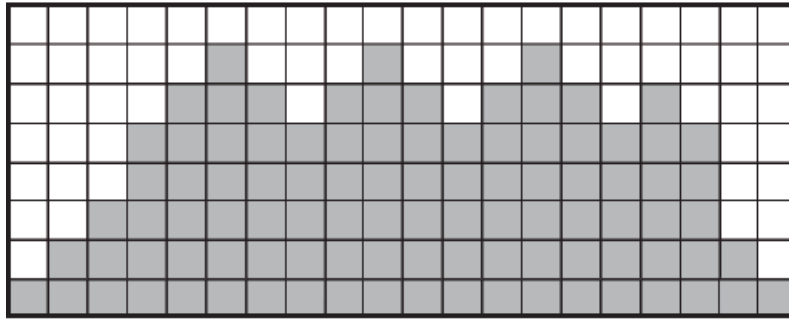

**STRENGTH**

This program has a gradual progression of resistance up to 100% of maximum effort that is sustained for 25% of the workout duration. This will help build strength and endurance in the lower body and glutes. Cool down follows.

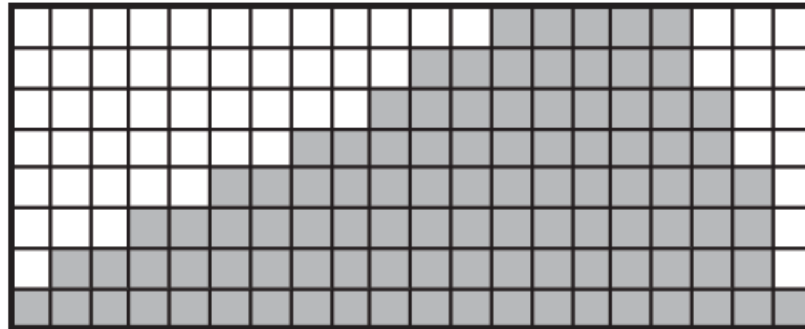

**INTERVAL**

This program takes you through high levels of intensity followed by recovery periods of low intensity. This program utilizes and develops your “Fast Twitch” muscle fibers which are used when performing tasks that are intense and short in duration. These deplete your oxygen level and spike your heart rate, followed by periods of recovery and heart rate drop to replenish oxygen. Your cardiovascular system gets programmed to use oxygen more efficiently.

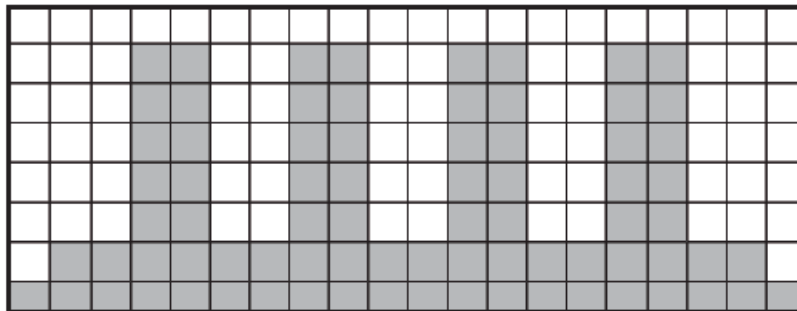

**HR**

The default value is 65% of your projected rate maximum. You have the option of changing your target heart rate. The machine will attempt to keep you within five beats of your target heart rate.

**CUSTOM**

You will create the desired resistance for each of the 20 segments of the program using the pop-out keyboard on this screen. After the program has started, you still have the ability of changing the resistance levels whenever you desire.

**FIT TEST PROGRAM**

The Fit Test is based on the YMCA protocol, which is a sub-maximal VO2 test based on your heart rate. The test consists of up to 4 stages. The resistance level increases at the end of each stage until you reach 85% of the projected maximum heart rate or 2 consecutive stages over 110 beats per minute. You will receive a score after

the test is completed.

**NOTE:** use a heart rate strap for best results.

### **Before The Test:**

- Make sure you are in good health; check with your physician before performing any exercise if you are over the age of 35 or persons with pre-existing health conditions.
- Make sure you have warmed up and stretched before taking the test.
- Do not take in caffeine before the test.
- Hold the hand grips gently, do not tense up.

### **During The Test:**

- The console must be receiving a steady heart rate for the test to begin. You may use the hand pulse sensors or wear a heart rate chest strap transmitter.
- You must maintain a steady 50 rpm pedal speed. If your pedal speed drops below 48 rpm or goes above 52 rpm the console will emit a steady beeping sound until you are within this range.
- You may scroll through the various data readings by pressing the Display button under the Message Window.
- The Message Window will always display your pedal speed on the right side to help you maintain 50 rpm.
- The data shown during the test is:
  - Work in KGM is actually an abbreviated form of kg-m/min. which is a work measurement of kilogram-force meter/minute
  - Work in Watts (1 watt is equal to 6.11829727787 kg-m/min.)
  - HR is your actual heart rate; TGT is the target heart rate to reach to end the test.
  - Time is the total elapsed time of the test.

### **After The Test:**

- Cool down for about one to three minutes.
- Take note of your score because the console will automatically return to the start-up mode after a few minutes.

### **What Your Score Means:**

- VO2MAX CHART FOR MALES AND VERY FIT FEMALES

	18-25 years old	26-35 years old	36-45 years old	46-55 years old	56-65 years old	65+ years old
excellent	>60	>56	>51	>45	>41	>37
good	52-60	49-56	43-51	39-45	36-41	33-37
above average	47-51	43-48	39-42	35-38	32-35	29-32
average	42-46	40-42	35-38	32-35	30-31	26-28
below average	37-41	35-39	31-34	29-31	26-29	22-25
poor	30-36	30-34	26-30	25-28	22-25	20-21
very poor	<30	<30	<26	<25	<22	<20

- VO2MAX CHART FOR FEMALES AND DECONDITIONED MALES

	18-25 years old	26-35 years old	36-45 years old	46-55 years old	56-65 years old	65+ years old
excellent	56	52	45	40	37	32
good	47-56	45-52	38-45	34-40	32-37	28-32
above average	42-46	39-44	34-37	31-33	28-31	25-27
average	38-41	35-38	31-33	28-30	25-27	22-24
below average	33-37	31-34	27-30	25-27	22-24	19-22
poor	28-32	26-30	22-26	20-24	18-21	17-18
very poor	<28	<26	<22	<20	<18	<17

### CONSTANT POWER

A watts program is a controllable constant power whose level adjusts when the speed is changed. Choose either faster pedaling at a lower resistance level or slower pedaling at a higher resistance level.

### GENERAL MAINTENANCE



Wipe down all areas in the sweat path with a damp cloth after each workout. If a squeak, thump, clicking or rough feeling develops the main cause is most likely one of two reasons:

1. The hardware was not sufficiently tightened during assembly. All bolts that were installed during assembly need to be tightened as much as possible. It may be necessary to use a larger wrench than the one provided if you cannot tighten the bolts sufficiently. It is important to note that 90% of calls to the service department for noise issues can be traced to loose hardware.
2. The crank arm nut needs to be retightened. If squeaks or other noises persist, check that the unit is properly leveled. There are 2 leveling pads on the bottom of the rear stabilizer, use a 14mm wrench (or adjustable wrench) to adjust the levelers.

## **SANITIZING YOUR SPIRIT FITNESS EQUIPMENT**

- Unupholstered high-contact surfaces (hard plastics) can be sanitized using a 75% isopropyl alcohol solution and a clean, dry cloth. Spray surfaces to be sanitized, and use the dry cloth to wipe clean. Allow surfaces to dry before using.
- For upholstered or soft-plastic surfaces, use a conditioner after sanitizing. Be sure to follow the instructions provided by the conditioner manufacturer to ensure proper use of the conditioner.
- Alternatively, you can make your own spray by mixing the proper ratio of isopropyl alcohol and distilled water to reach a 75% solution.
- For more details on sanitization, or to learn how to make your own spray solution, please visit <https://support.spiritfitness.com/hc/en-us/articles/4406787148564>.

## **FITNESS BIKE WARRANTY EFFECTIVE NOVEMBER 8, 2021**

Spirit Fitness warrants this fitness bike for a period of time listed below from the date of sale, as determined by sale receipt, or in the absence of a sales receipt eighteen (18) months from the original factory shipping date. Spirit Fitness' responsibilities include providing new or remanufactured parts, at Spirit Fitness' option, and technical support to our independent dealers and servicing organizations. In the absence of a dealer or service organization, these warranties will be administered by Spirit Fitness directly. The warranty period applies to the following components:

Prisons and correctional facilities are excluded from warranty coverage.

## **NORMAL RESPONSIBILITIES OF THE FACILITY**

The facility is responsible for the items listed below:

1. The warranty registration card must be completed and returned to the address listed on the card within 10 days of the original purchase, or completed online to validate the manufacturer's limited warranty.
2. Proper use of the fitness equipment in accordance with the instructions provided in this manual
3. Proper installation in accordance with instructions provided with the fitness equipment and with all local electric codes.
4. Expenses for making the fitness equipment accessible for servicing, including any item that was not part of the fitness equipment at the time it was shipped from the factory.
5. Damages to the fitness equipment finish during shipping, installation or following installation.

6. Routine maintenance of this unit as specified in this manual.

## **EXCLUSIONS**

This warranty does not cover the following:

1. CONSEQUENTIAL, COLLATERAL, OR INCIDENTAL DAMAGES SUCH AS PROPERTY DAMAGE AND INCIDENTAL EXPENSES RESULTING FROM ANY BREACH OF THIS WRITTEN OR ANY IMPLIED WARRANTY. NOTE: Some states do not allow the exclusion or limitation of incidental or consequential damages, so this limitation or exclusion may not apply to you.
2. Service call reimbursement to the facility. Service call reimbursement to the dealer that does not involve malfunction or defects in workmanship or material, for units that are beyond the warranty period, for units that are beyond the service call reimbursement period, for fitness equipment not requiring component replacement, or fitness equipment not in non-dues paying facility or household use.
3. Damages caused by services performed by persons other than authorized Spirit Fitness service companies; use of parts other than original Spirit Fitness parts; or external causes such as corrosion, discoloration of paint or plastic, alterations, modifications, abuse, misuse, accident, improper maintenance, inadequate power supply, or acts of God.
4. Products with original serial numbers that have been removed or altered.
5. Products that have been: sold, transferred, bartered, or given to a third party.
6. Products that do not have a warranty registration card on file at Spirit Fitness. Spirit Fitness reserves the right to request proof of purchase if no warranty record exists for the product.
7. THIS WARRANTY IS EXPRESSLY IN LIEU OF ALL OTHER WARRANTIES EXPRESSED OR IMPLIED, INCLUDING THE WARRANTIES OF MERCHANTABILITY AND/OR FITNESS FOR A PARTICULAR PURPOSE.
8. Product used in prisons and correctional facilities

**Warranties** outside of the United States may vary. Please contact your local dealer for details.

## **SERVICE**

Keep your bill of sale. Twelve (12) months from the date on the bill of sale or eighteen (18) months from the date of factory shipping as determined by the serial number establishes the labor warranty period should service be required. If service is performed, it is in your best interest to obtain and keep all receipts. This written warranty gives you specific legal rights. You may also have other rights that vary from state to state. Service under this warranty must be obtained by following these steps, in order:

1. Contact your selling authorized Spirit Fitness dealer. OR
2. Contact your local authorized Spirit Fitness service organization.
3. If there is a question as to where to obtain service, contact our service department at (870) 935-1107.
4. Spirit Fitness' obligation under this warranty is limited to repairing or replacing, at Spirit Fitness' option, the product through one of our authorized service centers. All repairs must be preauthorized by Spirit Fitness.
5. The owner is responsible for adequate packaging upon return to Spirit Fitness. Spirit Fitness is not responsible for damages in shipping. Make all freight damage claims with the appropriate freight carrier. DO NOT SHIP ANY UNIT TO OUR FACTORY WITHOUT A RETURN AUTHORIZATION NUMBER. All units arriving without a return authorization number will be refused.

6. For any further information, or to contact our service department by mail, send your correspondence to:

SPIRIT FITNESS, INC.

P.O. Box 2037

Jonesboro, AR 72402-2037

Product features or specifications as described or illustrated are subject to change without notice. All warranties are made by Spirit Manufacturing, Inc. This warranty applies only in the 48 contiguous United States. NOTE: This does not apply to Alaska or Hawaii.

800.258.4555 [spiritservice@spiritfitness.com](mailto:spiritservice@spiritfitness.com) [www.spiritfitness.com](http://www.spiritfitness.com)

Spirit Fitness 3000 Nestle Road Jonesboro, AR 72401

CR900ENT Owners Manual © 2021 All Rights

**Reserved Revision:** 11.08.2021

## Documents / Resources

	<p><a href="#">SPIRIT CR900ENT Fitness Bike</a> [pdf] Owner's Manual CR900ENT Fitness Bike, CR900ENT, Fitness Bike, Bike</p>
---	--

## References

- [P65Warnings.ca.gov](http://P65Warnings.ca.gov)

Manuals+