



FMS MG41 1:24 FCX24 Power Wagon User Manual

[Home](#) » [Fms](#) » FMS MG41 1:24 FCX24 Power Wagon User Manual 

Contents

- 1 FMS MG41 1:24 FCX24 Power Wagon
- 2 Product Information
- 3 Product Usage Instructions
- 4 SAFETY PRECAUTIONS
 - 4.1 Introduction
- 5 FCC Compliance Statement
- 6 RADIO SYSTEM
 - 6.1 Safety guide
- 7 PRODUCT INTRODUCTION
 - 7.1 Background
 - 7.2 Features
 - 7.3 About Model
 - 7.4 Specification
 - 7.5 Transmitter instruction
 - 7.6 Overview
 - 7.7 Binding
 - 7.8 ESC Parameter Setting
 - 7.9 Parameter Explanation
- 8 Lighting function
- 9 Getting started
- 10 Instructions
- 11 THROTTLE STICK POSITION
- 12 VEHICLE SETUP
- 13 OPERATING THE VEHICLE
- 14 Spare parts list
- 15 Roll Cage installation
- 16 Finished Frame Sets
- 17 Wheels
- 18 Frame Sets
- 19 Two speed transmission Installation
- 20 Documents / Resources
- 21 Related Posts



FMS MG41 1:24 FCX24 Power Wagon



Product Information

The 1:24 FCX24 Power Wagon is an off-road vehicle designed for racing. Its specifications include:

- Length: 210mm
- Width: 124mm
- Height: 132mm
- Wheel base: 138mm
- 2.4GHz Controller Equipment Class: 2

Product Usage Instructions

Safety Precautions:

- This product is not a toy and is recommended for ages 14 and up. Adult supervision is required for ages under 14 years old.
- Contains small parts, keep out of reach of children 3 years of age and younger.
- Minimum distance of 20cm between the radiator and your body should be maintained during operation.

CE Compliance Information:

The following countries recognize the certifications for this product as authorized for sale and use:

FCC Compliance:

- This device complies with Part 15 of the FCC Rules.
- Operation is subject to the following two conditions: (1) this device may not cause harmful interference, and (2) this device must accept any interference received, including interference that may cause undesired operation.
- RF exposure compliance should be maintained with minimum distance of 20cm between the radiator and your body.

Environmentally Friendly Disposal:

- Old electrical appliances must not be disposed of together with the residual waste, but have to be disposed of separately.
- The disposal at the communal collecting point via private persons is for free.
- The owner of old appliances is responsible to bring the appliances to these collecting points or to similar collection points.

Product Introduction:

The MUD MASTER is an annual off-road vehicle race held in Manchac, near New Orleans, Louisiana. The race is open to anyone with a minimum FIA C1 licence. It does not accept registrations or sponsorships from car manufacturers' teams and does not allow the manufacturer's logo to be exposed. A significant portion of the competition's operating income is donated to local active environmental organizations for conservation and earth science education.

SAFETY PRECAUTIONS

Introduction

This manual is written to assist you in properly operating, maintaining and repairing the vehicle. As many of the components used are unique to this truck, please retain this manual as a future reference. Composed of precision-made components, this product not a toy, thus it is not suited for children under 14 years of age. Minors should be accompanied by an adult when operating. Failure to operate or maintain this vehicle in a safe manner can result in bodily harm. It is the owner responsibility to operate this product in a safe manner, and its distributors are not responsible in any way for any and all bodily harm and/ or property damage that may result from the use of this product. Replace damaged components with original factory-parts. Pay special attention to the polarity of all vehicle wiring.

Safety, precautions and warnings

- Replace damaged components with original factory-parts. Pay special attention to the polarity of all vehicle wiring.
- Use common sense when selecting the environment to operate your vehicle. Do not operate near power cables, cellular/radio towers, deep water or unstable terrain. The operator is solely responsible for their actions.
- The product is composed of precision electrical components. It is critical to keep the product away from moisture and other contaminants.
- Always check the radio range of the vehicle prior to operation in order to prevent radio loss or interference.
- Operate this product within your ability. If the vehicle is dangerous to retrieve, it never worth the risk.
- Always turn on the transmitter before connecting the battery on the model. When turning off the model, always disconnect the battery first, and then turn off the model, always disconnect the battery first, and then turn off the transmitter. If this order is reversed, the model may become uncontrollable and cause serious damage.
- Never allow transmitter batteries to run low as it may cause loss of vehicle control.
- Plastics on the vehicle are susceptible to damage or deformation due to extreme heat and cold climate. Do not store the model near any source of heat such as oven or heater. Store the model indoors, in a climate-controlled, room temperature environment.

CE compliance information for the european union

The associated regulatory agencies of the following countries recognize the noted certifications for this product as authorized for sale and use.

UK	DE	DK	BG	SE	GZ	ES	NL	SK	HU	RO	FR	PT	BE
FI	EE	LV	LT	PL	AT	CY	SI	GR	MT	IT	IE	LU	

Declaration of Conformity

Products: 2.4GHz Controller

Equipment Class: 2

The objects of declaration described above are in conformity with the requirements of the specifications listed below.

Item Name : 2.4GHz Controller

The RED Directive 2014/53/EU

EN 60950-1:2006 + A11:2009 + A1:2010

+ A12:2011 + A2:2013

EN 300 328 V2.2.2 (2019-07)

EN 301 489-1 V2.1.1:2017

EN 301 489-17 V3.1.1:2017

This product is not a toy! (14+) Recommended for ages 14 and up. Adult supervision required for ages under 14 years old. Contains small parts, keep out of reach of children 3 years of age and younger.

Certification

FCC Compliance Statement

This device complies with Part 15 of the FCC Rules. Operation is subject to the following two conditions: (1) this device may not cause harmful interference, and (2) this device must accept any interference received, including interference that may cause undesired operation.

Warning: changes or modifications not expressly approved by the party responsible for compliance could void the user's authority to operate the equipment.

This equipment has been tested and found to comply with the limits for a Class B digital device, pursuant to Part 15 of the FCC Rules. These limits are designed to provide reasonable protection against harmful interference in a residential installation. This equipment generates, uses and can radiate radio frequency energy and, if not installed and used in accordance with the instructions, may cause harmful interference to radio communications. However, there is no guarantee that interference will not occur in a particular installation. If this equipment does cause harmful interference to radio or television reception, which can be determined by turning the equipment off and on, the user is encouraged to try to correct the interference by one or more of the following measures:

1. Reorient or relocate the receiving antenna.
2. Increase the separation between the equipment and receiver.
3. Connect the equipment into an outlet on a circuit different from that to which the receiver is connected.
4. Consult the dealer or an experienced radio/TV technician for help.

RF Exposure Compliance

This equipment complies with FCC radiation exposure limits set forth for an uncontrolled environment. This equipment should be installed and operated with minimum distance 20cm between the radiator and your body. This transmitter must not be co-located or operating in conjunction with any other antenna or transmitter.

Environmentally friendly disposal

Old electrical appliances must not be disposed of together with the residual waste, but have to be disposed of

separately. The disposal at the communal collecting point via private persons is for free.

The owner of old appliances is responsible to bring the appliances to these collecting points or to similar collection points. With this little personal effort, you contribute to recycle valuable raw materials and the treatment of toxic substances.

RADIO SYSTEM

Safety symbols

Pay close attention to the following symbols and their meanings. Failure to follow these warnings could cause damage, injury or death.

Attention Not following these instructions may lead to minor injuries.

Warning Not following these instructions may lead to major injuries.

Danger Not following these instructions may lead to serious injuries or death.

Safety guide



Prohibited



Mandatory

- Do not use the product at night or in bad weather like rain or thunderstorm. It can cause erratic operation or loss of control.
- Do not use the product when visibility is limited.
- Do not use the product on rain or snow days. Any exposure to moisture (water or snow) may cause erratic operation or loss of control.
- Interference may cause loss of control. To ensure the safety of you and others, do not operate in the following places:
 - Near any site where other radio control activity may occur
 - Near power lines or communication broadcasting antennas
 - Near people or roads
 - On any body of water when passenger boats are present
- Do not use this product when you are tired, uncomfortable, or under the influence of alcohol or drugs. Doing so may cause serious injury to yourself or others.
- The 2.4GHz radio band is limited to line of sight. Always keep your model in sight as a large object can block the RF signal and lead to loss of control.
 - Do not touch any part of the model that may generate heat during operation, or immediately after use. The engine, motor or speed control, may be very hot and can cause serious burns.
- Misuse of this product may lead to serious injury or death. To ensure the safety of you and your equipment, read this manual and follow the instructions.
- Make sure the product is properly installed in your model. Failure to do so may result in serious injury.
- Make sure to disconnect the receiver battery before turning off the transmitter. Failure to do so may lead to unintended operation and cause an accident.
- Ensure that all motors operate in the correct direction. If not, adjust the direction first.
- Make sure the model stays within the systems maximum range to prevent loss of control.

PRODUCT INTRODUCTION

Background

The MUD MASTER is held every June in Manchac, near New Orleans, Louisiana, where there are dense swamps, rugged rocks, and dead woods, making it difficult for off-road vehicles to move.

- Legend has it that this area was cursed by the Queen of Voodoo Mary Poppin, and there is a mysterious singing that attracts people to get lost in the jungle, and there is no return. The swamp is also home to giant alligators that can devour adults..The stories were chilling, but they drew waves of young people who ventured into this no-man's land, deep into the swampy hinterland, and garnered attention by sharing their location on Twitter. There are many people going in, and there are occasional unfortunate disappearances. But instead of deterring people from entering, it acts like a magnet to attract more visitors.
- In fact, this is a very beautiful ancient forest. The founder of the race, Chandler Bing, was born and raised on a nearby farm. He believes that no matter how powerful the vehicle is, it is difficult to pass here, and no matter how deep the rut is, it is difficult to maintain a week. Human beings are insignificant in front of nature and should live full of humility and awe under the protection of nature. Therefore, in 2007.01.01, the MUD MASTER cross-country race was established to test the limits of people and machines, and at the same time, let the audience feel the pure power of nature. Mary Poppin is his college teacher and his second wife, alligators are a traditional local delicacy, and Gator Tail Bites is the most popular dish among racers.
- The race is open to anyone with a minimum FIA C1 licence. However, it does not accept registrations or sponsorships from car manufacturers' teams, and does not allow the manufacturer's logo to be exposed. The purpose is to limit the entry of large capital and high technology, and to make the competition pure and simple. A significant portion of the competition's operating income is donated to local active environmental organizations for conservation and earth science education.
- After 12 years of development, the scale and influence of the event has expanded year by year. In 2019, it was absorbed by the Amazon Rainforest Challenge and became the largest off-road racing carnival in the world. In recent years, with the advancement of electric vehicle technology, the proportion of hybrid racing cars is getting higher and higher, and pure electric vehicles have begun to join in 2021. Due to the extremely complex environment, most racing cars choose to install tractor tires. The huge herringbone pattern has a good mud removal effect. The customized short wheelbase chassis ensures the longitudinal passability of the racing car, and the portal axle is just starting line.
- The initial participants were mostly local farmers, ranchers and crocodile breeders who had years of experience scrambling around in the mud, which is why their cars looked so much like tractors. William Butch is a newcomer to the event in 2020. His father is a large local cattle farmer, and he himself is responsible for the slaughter and beef sales. People nicknamed him Butcher. His car uses a lot of parts from agricultural vehicles, and the casing comes from the legacy of his uncle Douglas Butch, a 1949 POWER WAGON.

Because of the sturdy driving style, not playing cards according to common sense, and being familiar with the local climate and terrain, he has repeatedly won by surprise. Soon, the name of "Butcher Butch" spread.

To be continued...

Features

- Ready to run model

- Two speed transmission
- Portal axle
- 24 ball bearings full set
- Metal gears steering servo
- Four link suspension
- Power wagon polystyrene body
- Rapid separation car body
- Nylon roll cage
- Painted body
- Remote control lighting system
- Original personalized stickers

About Model

As the first product of the FCX24 series, the car body is the POWER WAGON in 1949, which appeared in the form of a mud off-road truck. We put the reason and future development in this story to share with you.

2.4G 4-channel digital proportional remote control system, in addition to normal driving and steering control, the CH3 is used to control shifting, and the CH4 is reserved for players' imagination expansion. It is also equipped with a lighting control module, and the headlights can be switched between high and low beams. In addition, interfaces for taillights and turn lights are reserved for players to modify.

Unlike previous FMS products, FCX24 focuses more on sports performance. A large number of upgraded and modified parts such as metal gears, shock absorbers, high-performance motors, radiators, and wheel hub counterweights will be launched simultaneously. Players from all over the world, look forward to you creating your own unique FCX24.

As the first product of the FCX24 series, the car body is the POWER WAGON in 1949, which appeared in the form of a mud off-road truck. We put the reason and future development in this story to share with you.

2.4G 4-channel digital proportional remote control system, in addition to normal driving and steering control, the CH3 is used to control shifting, and the CH4 is reserved for players' imagination expansion. It is also equipped with a lighting control module, and the headlights can be switched between high and low beams. In addition, interfaces for taillights and turn lights are reserved for players to modify.

Unlike previous FMS products, FCX24 focuses more on sports performance. A large number of upgraded and modified parts such as metal gears, shock absorbers, high-performance motors, radiators, and wheel hub counterweights will be launched simultaneously. Players from all over the world, look forward to you creating your own unique FCX24.

Specification

- Length : 210mm
- Width : 125.7mm
- Height : 131mm
- Wheelbase : 138.8mm
- Tire F/R Φ 60 × 20mm
- Minimum Ground Clearance 38.8mm
- Approach Angle 67.7°
- Departure Angle > 90 °
- Reduction ratio (High Gears) 24.75 (Low Gears) 99

Transmitter instruction

Intruccion

FS-R4A1 based on ANT protocol is a three-in-one receiver with ESC and LED light group control board. It has an external single antenna, can output PWM signal and light control signal, can implement two-way transmission, adopts automatic binding, and has a compact design, which can be adapted to various model cars.

TransmitterOverview

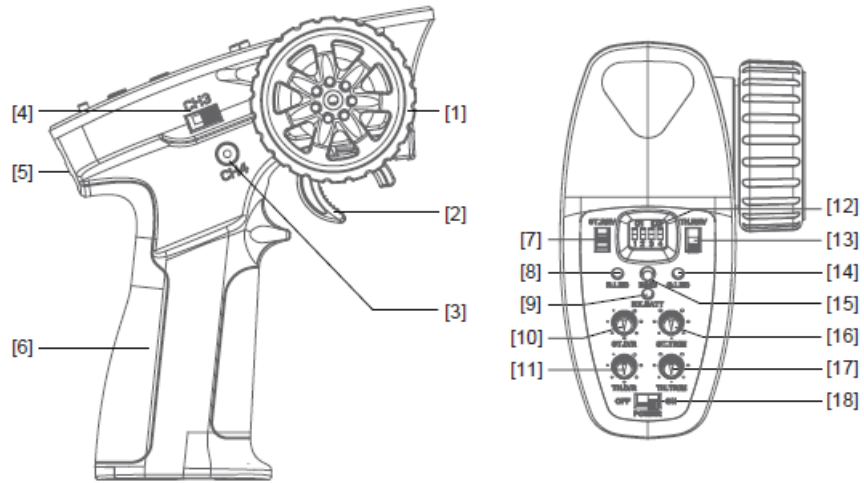

[1]	Traversing handwheel, 35 degrees on each side (CH1)	[10]	ST.D/R
[2]	Throttle button, 25 degrees in front and 12.5 degrees at rear (CH2)	[11]	TH.D/R
[3]	Push button switch (CH4) [Push button function is flip type]	[12]	Switch to the electric adjustment mode
[4]	Three-position toggle switch (CH3)	[13]	TH.REV
[5]	Lanyard hole	[14]	G.LED
[6]	Handle, 4*AAA battery compartment	[15]	BIND
[7]	ST.REV	[16]	ST.TRIM
[8]	R.LED	[17]	TH.TRIM
[9]	RX.BATT	[18]	Power Switch

Overview

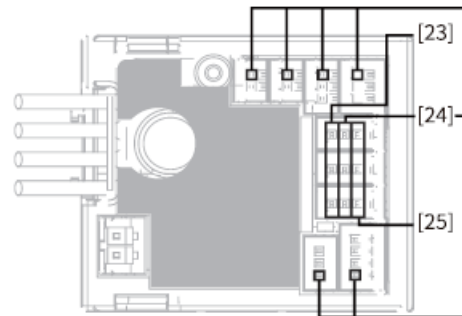
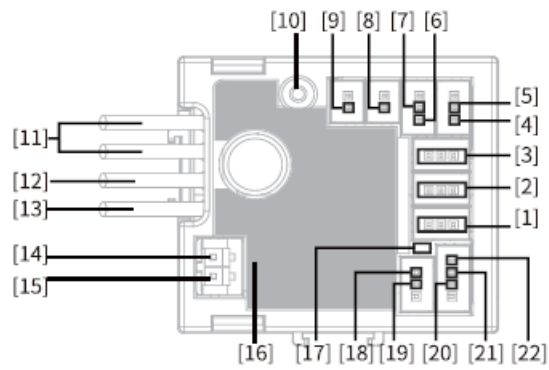

1. CH1
2. CH3
3. CH4
4. Left-turn light port
5. Head light port
6. Right-turn light port
7. Head light port
8. Fog light port
9. Fog light port
10. Antenna
11. Power switch
12. Battery line “+”
13. Battery line “-“
14. Motor port “+”
15. Motor port “-“
16. Stickers
17. LED
18. Left-turn light port
19. Right-turn light port
20. Reversing light port
21. Brake light port
22. Taillight port
23. Signal pin
24. Power “+”
25. Power “-“

Specifications

- Product Name: FS-R4A1
- Adaptive transmitter: FS-MG41
- Model Type: Car
- Channels: 4
- Numbers of Light Interfaces: 7
- RF: 2.4GHz ISM
- 2.4G Protocol: ANT
- Antenna: Single antenna
- Input Power: Lipo (2S)/NiMH (5~7Cell)
- BEC Output: 6V/1A
- Continuous/Peak Current: 10A/50A
- Data Output: PWM
- Temperature Range: -10°C —+60°C
- Humidity Limit: 20%~95%
- WaterProof: PPX4
- Online Update: No
- Dimensions: 33mm*30mm*12mm
- Weight: About 11g
- Certification: CE, FCC ID: N4ZR4A10

Binding

The receiver automatically enters the binding state once it is powered on.

Press the BIND Key to turn on the transmitter and allow it to enter its binding state. Here, G.LED flashes quickly, and operator releases the BIND Key.

1. When the receiver is powered on and waits for 1 second, it will automatically enter the binding state if it is not connected;
2. After the binding is successful, the LED indicator of the receiver is always on.

Notes: (1) Set the transmitter to its binding state first, and then set the receiver to its binding state. If the binding is not completed within 10s, the indicator light of the receiver will enter its slow flashing state. (2) If re-binding is successful, all the settings of the car lights will be restored to their default values.

ESC protection

This receiver has multiple prompt functions such as power-on self-check display, overheating alarm prompt, and low/high voltage alarm prompt.

- Self-check display: all car lights will be on for 1S when the receiver is powered on;
- Overheating alarm: When the internal temperature of the ESC is detected to exceed 110 °C, motor has no output, all car lights flash promptly, and the normal output will be restored when the temperature is lower than 70°C;
- Low/high voltage alarm: When the receiver enters the low voltage protection, motor has no output, and all the lights flash slowly; when the receiver enters the high voltage protection, all channels have no output. All car lights flash promptly.

ESC function instructions

1. Connect related equipment:

Make sure the ESC is off before connection. Connect the motor with M+ and M- of ESC. Connect the steering servo to the 3Pin interface marked with "ST" of ESC (- + S connected correspondingly). Connect the battery with the positive and negative poles of ESC correspondingly.

2. Normal boot, identification throttle midpoint:

After connecting related equipment as step 1, turn on the radio first, move the throttle trigger to the neutral position. Turn on the switch of ESC at last. The receiver will automatically recognize the battery type when it is powered on again. Then it can run it.

Notes:

- The ESC can be run after completing self-inspection (about 3 seconds) if power on, otherwise it cannot be operated normally.
- If there is no power output and the red light of ESC flashes quickly after power on, please check whether the throttle trim of the transmitter is set to the "0" position, the receiver will automatically recognize the midpoint of the trim throttle after restarting;
- If the rotation direction is not correct during running, exchange the two wires connecting motor and ESC.
- To make sure everything is ok, please turn on the transmitter first and finally turn on the ESC, turn off the ESC first and finally turn off the transmitter.

Notes: Please refer to the relevant sections for details about the battery type, drag brake force and running mode of the ESC.

Failsafe









This function is used to protect the safety of the model and the operator when the receiver cannot normally receive the signal from the transmitter and is out of control. The receiver defaults that the throttle channel is fixed to be out of control and enters the brake state. After other channels are out of control, the receiver has no signal output. If you set it on the transmitter, it will output according to the set value.

Attention:

- Make sure the product is installed and calibrated correctly, failure to do so may result in serious injury.
- Please carefully check each power device and car frame instructions to ensure the power matching is reasonable before use. Avoid damaging power system due to incorrect matching.
- Do not let the external temperature of the system exceed 90°C /194°F , because high temperature will damage the power system.
- Make sure the receiver's battery is disconnected before turning off the transmitter, failure to do so may lead to unintended operation or loss of control.
- After use, remember to disconnect the battery and the ESC. If the battery isn't disconnected, the ESC will consume electric energy all the time even if it is off. It will discharge completely if connect the battery for a long time, thus resulting in the failure of the battery or the ESC. We are not responsible for any damage caused by this!
- Make sure the receiver is mounted away from motors or any device that emits excessive electrical noise.
- Keep the antenna of the receiver at least 1cm away from conductive materials such as carbon or metal.

- Do not power on the receiver during the setup process to prevent loss of control.

ESC Parameter Setting

Running Mode	Battery Type	Drag Brake	
 FWD/REV/BRK	 Lipo	 0%	 75%
 FWD/REV	 NiMH	 50%	 100%

Dial Switch sign

The Dial Switch on the transmitter is used to set ESC parameters, that is, the Dial Switch is located at different positions and the corresponding parameter values are different.

Setting Method:

There are three parameters can be set for the ESC, which are “Running mode”, “Battery type”, “Drag brake”, There are slide switches numbered 1 2 3 4 on the radio panel . The above parameters can be set by dialing down and up.

The specific operation is as follows:

- When No. 1 slide switch is on the down, it indicates that the operation mode is set to FWD / REV / BRK.
- When No. 1 slide switch is on the up, it indicates that the operation mode is set to FWD/REV. When No. 2 slide switch is on the down, it indicates that the battery type is set to Lipo.
- When No. 2 slide switch is on the up, it indicates that the battery type is set to NiMH.
- When No. 3 and No.4 slide switch are on the down, it indicates that the drag brake force is set to 0%.
- When No. 3 slide switch is on the down and No.4 slide switch is on the up, it indicates that the drag brake force is set to 50%.
- When No. 3 slide switch is on the up and No.4 slide switch is on the down, it indicates that the drag brake force is set to 75%.
- When No. 3 and No.4 slide switch are on the up, it indicates that the drag brake force is set to 100%.

Parameter Explanation

1. Running Mode

FWD/REV/BRK: This mode adopts “double click” reverse mode, that is, when the throttle trigger is pushed from neutral range to the reverse area for the first time, the motor is only braking and will not reverse; when the throttle trigger is moved back to the neutral range and pushed to the reverse area for the second time, it will reverse. This mode is applicable to general models.

FWD/REV: This mode adopts “one click” reverse mode, that is, when the throttle trigger is pushed from neutral range to the reverse area, the motor immediately generates reverse action, which is generally applied to rock crawler.

Parameter setting method:

When No. 1 slide switch is on the down, it indicates that the operation mode is set to FWD / REV / BRK.

When No. 1 slide switch is on the up, it indicates that the operation mode is set to FWD/REV.

2. Battery Type

There are LiPo and NiMH cells. The low-pressure protection value is different under different types. It can be set according to the actual use.

Parameter setting method:

When No. 2 slide switch is on the down, it indicates that the battery type is set to Lipo.

When No. 2 slide switch is on the up, it indicates that the battery type is set to NiMH.

3. Drag Brake Force

The drag brake means that when the throttle trigger moves from the forward or reverse area to neutral range, it will produce certain braking force to the motor, the larger the value is, the greater the drag brake force is. Select proper braking force according to the actual situation.

Parameter setting method:

When No. 3 and No.4 slide switch are on the down, it indicates that the drag brake force is set to 0%. When No. 3 slide switch is on the down and No.4 slide switch is on the up, it indicates that the drag brake force is set to 50%.

When No. 3 slide switch is on the up and No.4 slide switch is on the down, it indicates that the drag brake force is set to 75%.

When No. 3 and No.4 slide switch are on the up, it indicates that the drag brake force is set to 100%.

Lighting function

				Times for Pressing						
Button	Light Position	Function	Power on is off by default	I	II	III	IV	V	Control Mod	Remarks
CH4	Headlight	White headlights keep on		OFF	•	OFF	OFF	OFF		
		White headlights keep on with high brightness		OFF	OFF	•	•	OFF		

Getting started

Transmitter Battery Installation

Danger

- Only use specified battery (X4 AA batteries).
- Do not open, disassemble, or attempt to repair the battery.
- Do not crush/puncture the battery, or short the external contacts.
- Do not expose to excessive heat or liquids.
- Do not drop the battery or expose to strong shocks or vibrations.
- Always store the battery in a cool, dry place.
- Do not use the battery if damaged.

Battery Type: AAA
Battery Installation:

1. Open the battery compartment cover.
2. Insert 4 fully-charged AAA batteries into the compartment. Make sure that the battery makes good contact with the battery compartment's contacts.
3. Replace battery compartment cover.

Low battery alarm: When the battery is lower than 4.2V, the LED on the panel will flash slowly.

Instructions

After setting up, follow the instructions below to operate the system.

1. Automatic code matching (the transmitter and receiver have been successfully coded before leaving the factory.)

If you need to replace another transmitter or receiver, please follow the following steps to code:

1. When the transmitter power is on and the code matching mode is on, the light keeps flashing;
2. The power supply of the receiving board is turned on, and the front lights keep flashing to enter the code matching mode;
3. When the code matching is successful, all the transmitter lights are on and all the lights on the car are off;
Note: when code matching, please operate the transmitter to enter the code matching state first, and then operate the receiver to enter the code matching state.

THROTTLE STICK POSITION

Throttle stick position

Neutral point



Top point of forward direction



Top point of backward direction



VEHICLE SETUP

Connecting the battery

Step 1: Separate the car shell, the two buckles in the front of the car shell are opened outward, and the two buckles at the rear of the car shell are opened inward.

Step 2: Place the battery in the battery compartment on the frame and fix it with the attached rubber band.

Step 3: Connect the battery plug.

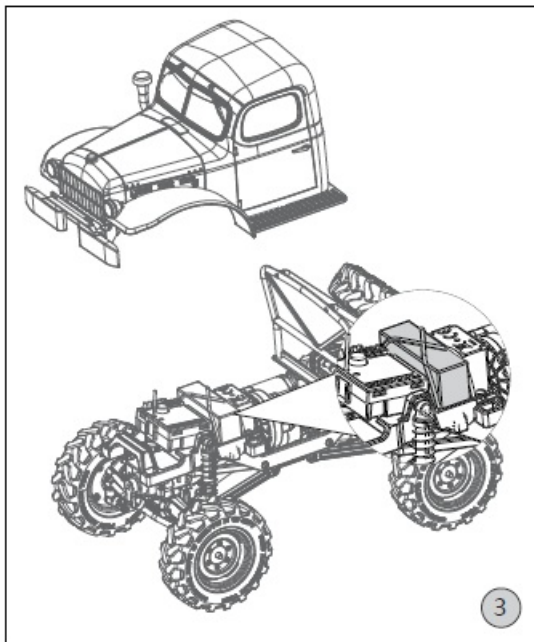
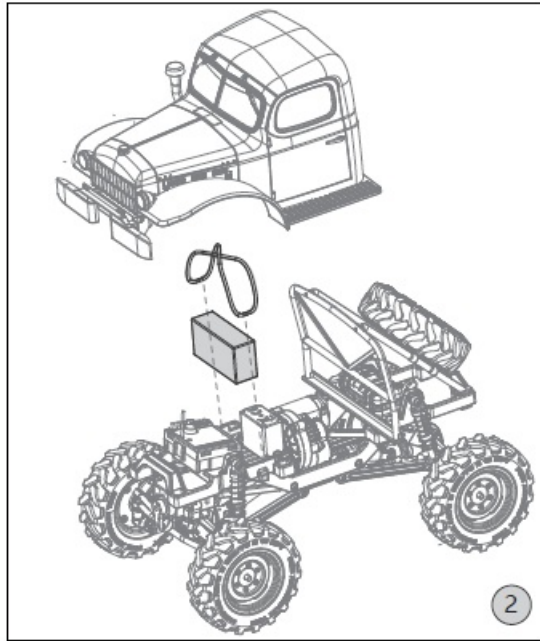
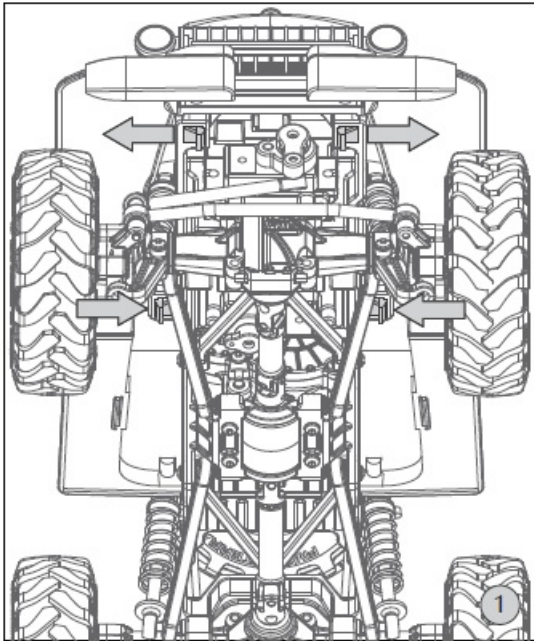

NOTE

1. If it is not in use for a long time, unplug and take off the battery to prevent battery leakage.
2. Do not open, disassemble, or attempt to repair the battery.
3. The battery needs to be disconnected from vehicle before it can be charged
4. Do not charge battery in vehicle.

OPERATING THE VEHICLE

Step 1: turn on the transmitter, the headlamp of the transmitter will flash and enter the frequency matching mode.

Step 2: turn on the receiver switch, the headlight will flash and enter the frequency matching mode.

Step 3: when the transmitter and receiver are successful in frequency up, the front lights of the transmitter will be on for a long time, and the front lights of the vehicle will be off.

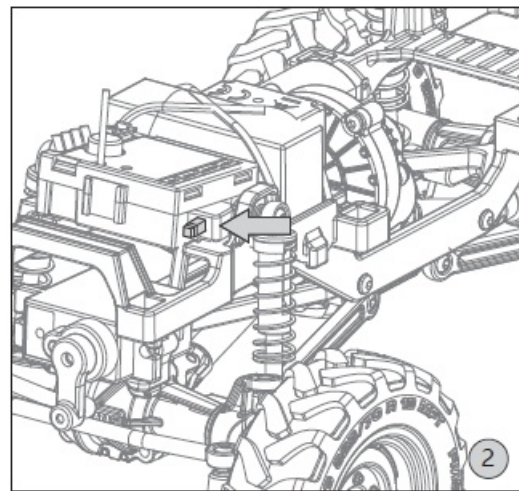
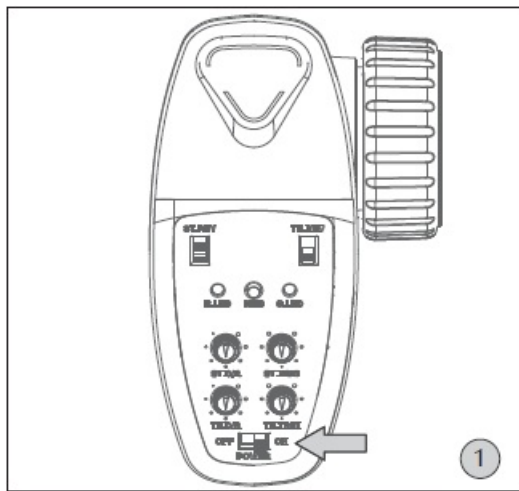

Spare parts list

C3040	Mud tire	C3023	Front dog bone set
C3000	Front bumper	C3024	Differential set
C3001	Girder	C3025	Cvd axle set
C3002	Oil shock absorbers assembly	C3026	Rear axle assembly
C3003	Wiper	C3027	Servo mount
C3004	Car body	C3028	Rod set
C3005	Windows	C3029	Servo horn set
C3006	Lens set	C3030	Pinion gear
C3007	Wheel	C3031	Bush
C3008	Snokle	C3032	130 motor
C3009	Side panel	C3033	Screw
C3010	Exhaustion plate	C3034	Screw nut
C3011	Window frame	C2131	MG41 + R4A1 transmitter receiver set
C3012	Transmission gear box assembly	C2122	MG41 transmitter
C3013	Transmission shaft	C2130	R4A1 esc/rx combo
C3014	Transmission gear box plastic	C3035	Steering servo
C3015	Gear set	C3036	Variable speed servo
C3016	Steering link set	C1389	FMS lipo battery 2s 380mah
C3017	Front axle assembly	C3037	Led light set
C3018	Axle plastic parts	C3038	Car decal sheet
C3019	Portal axle cover	C3039	Bearing set
C3020	C hub set	C3041	Fuel tank
C3021	Portal axle set	C3042	Anti roll bar
C3022	Rear wheel shaft set	C3043	Spare tire bracket

Roll Cage installation

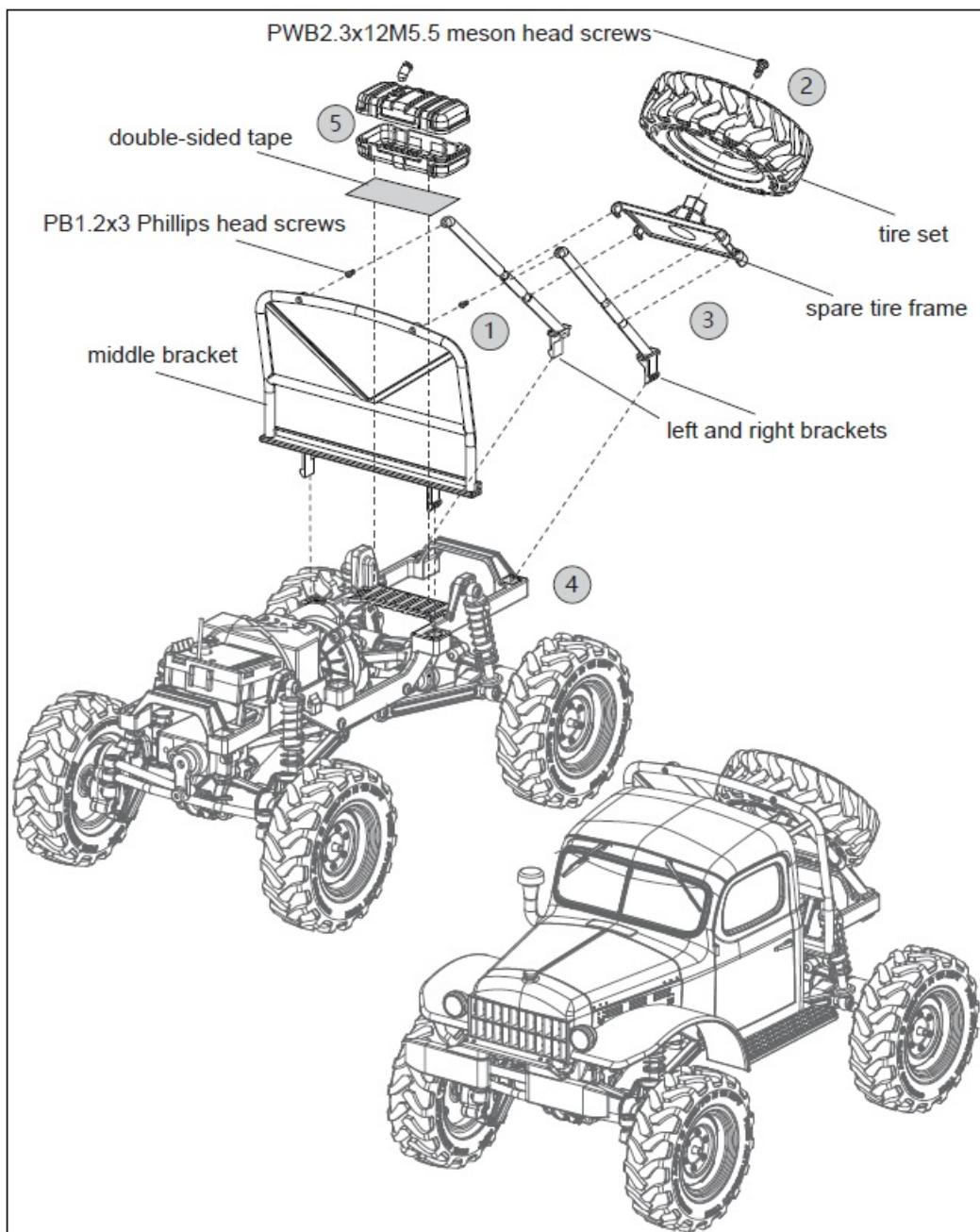

1. Use the included 2 PB1.2x3 Phillips head screws to install the left and right brackets on the middle bracket;
2. Use the included PWB2.3x12M5.5 meson head screws to install the tire set to the spare tire frame;
3. Install the assembled spare tire frame on the left and right brackets;
4. Install the assembled roll cage on the frame;
5. Use the included double-sided tape to stick the fuel tank to the corresponding position of the frame.

Finished Frame Sets

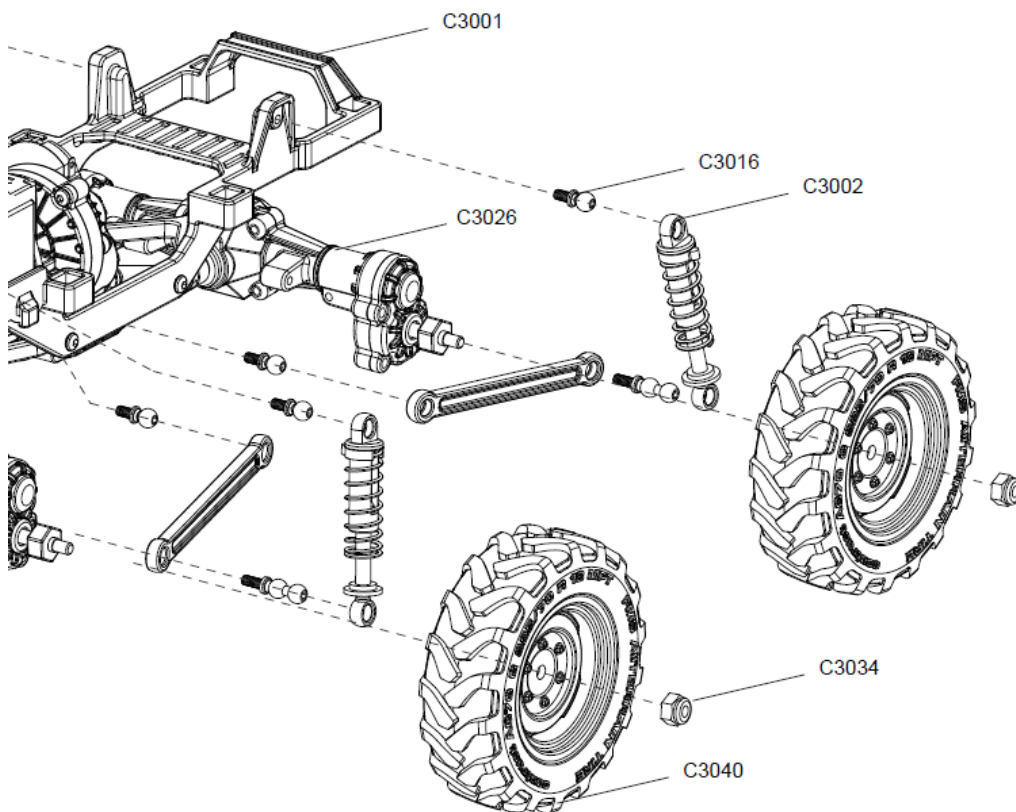
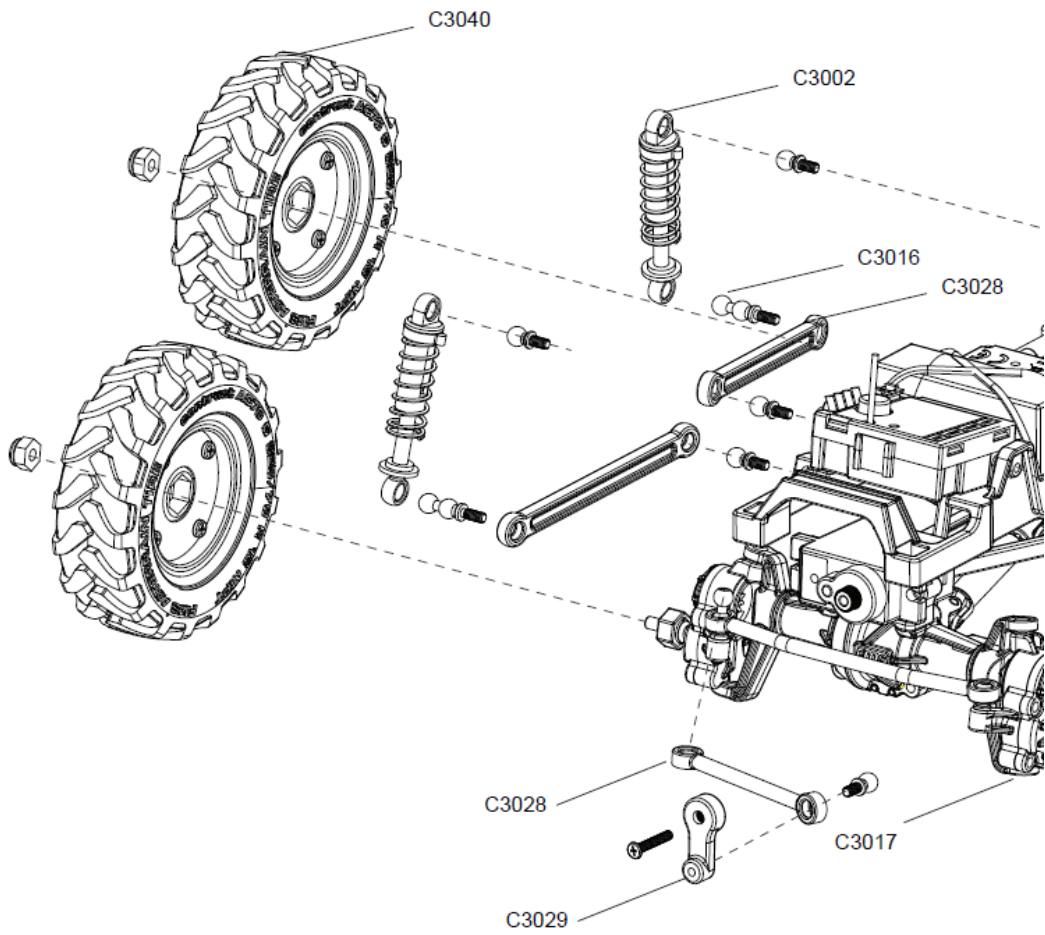

Wheels

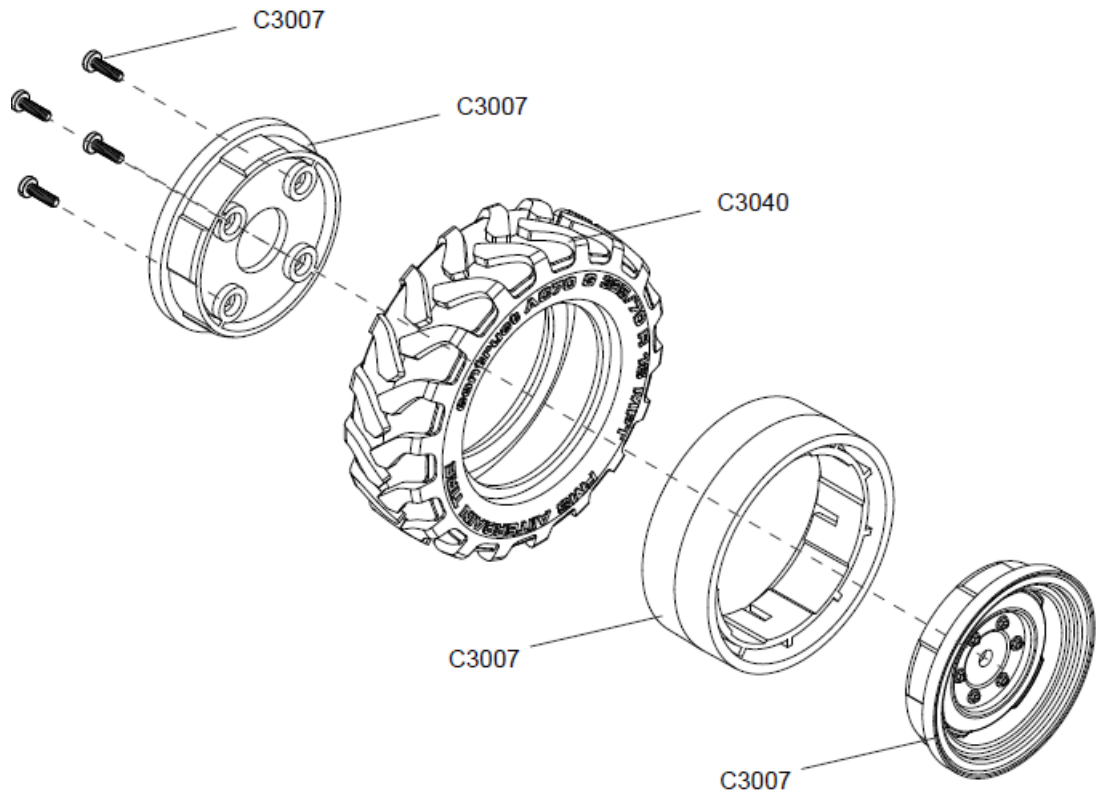

Frame Sets

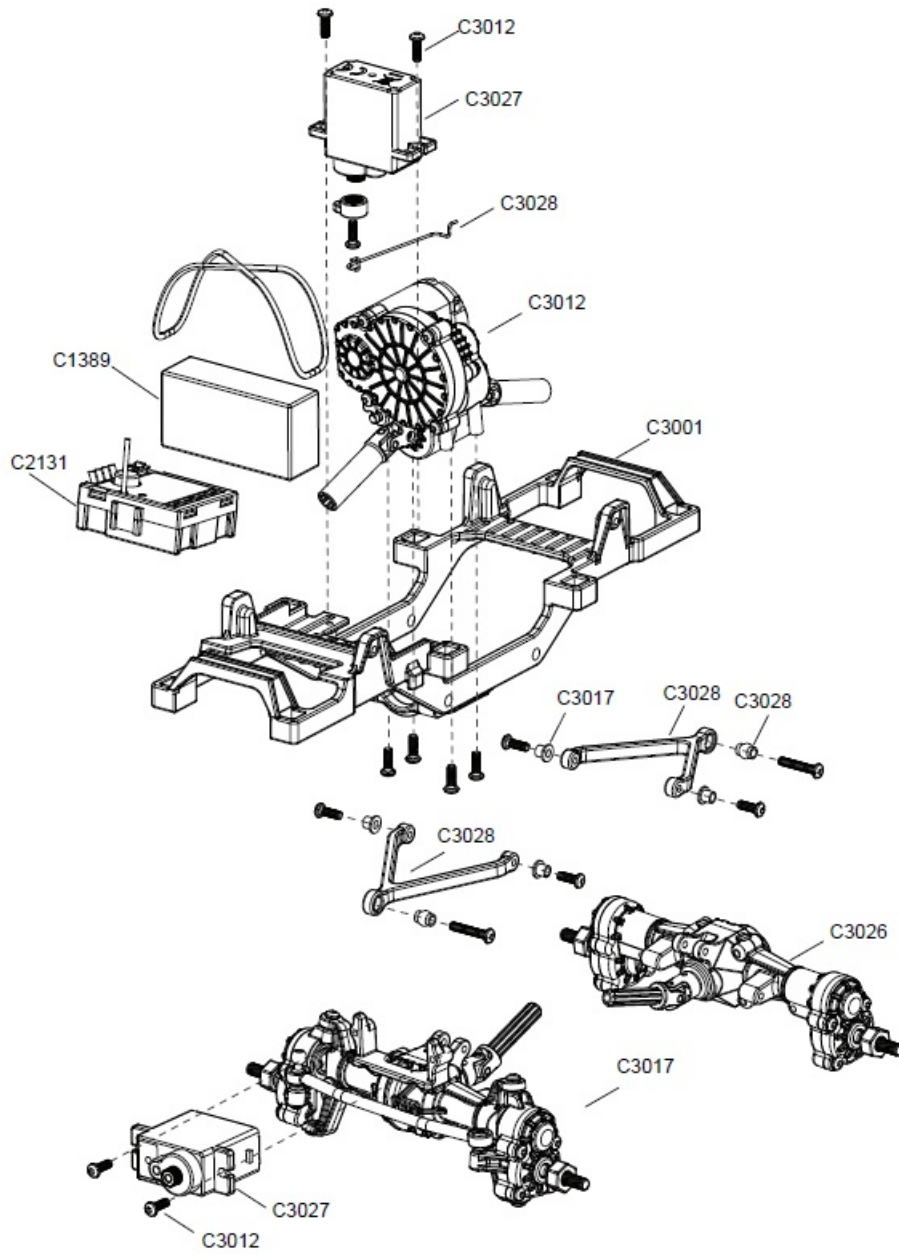

Front axle

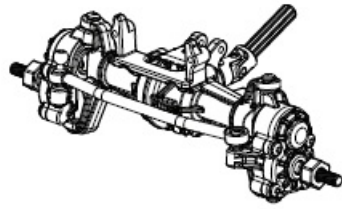

C3017

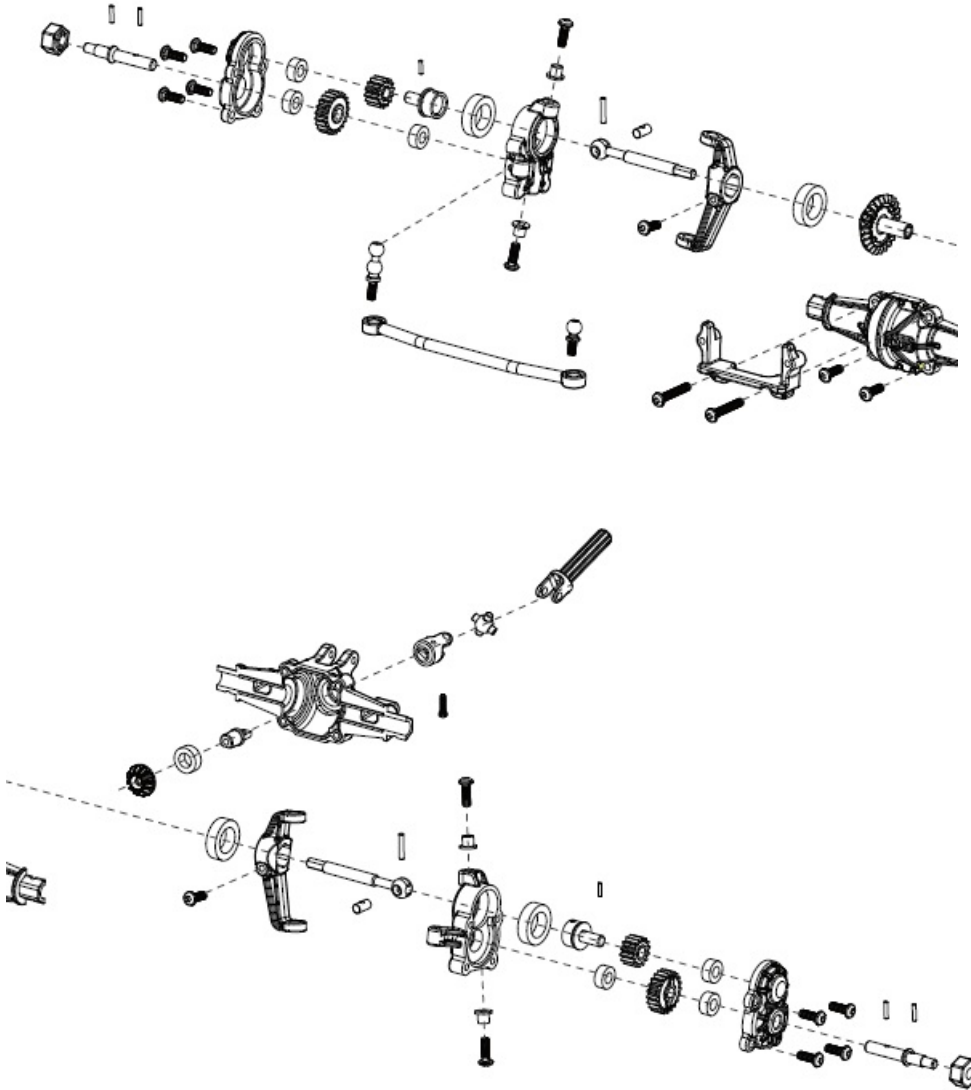

Rear axle

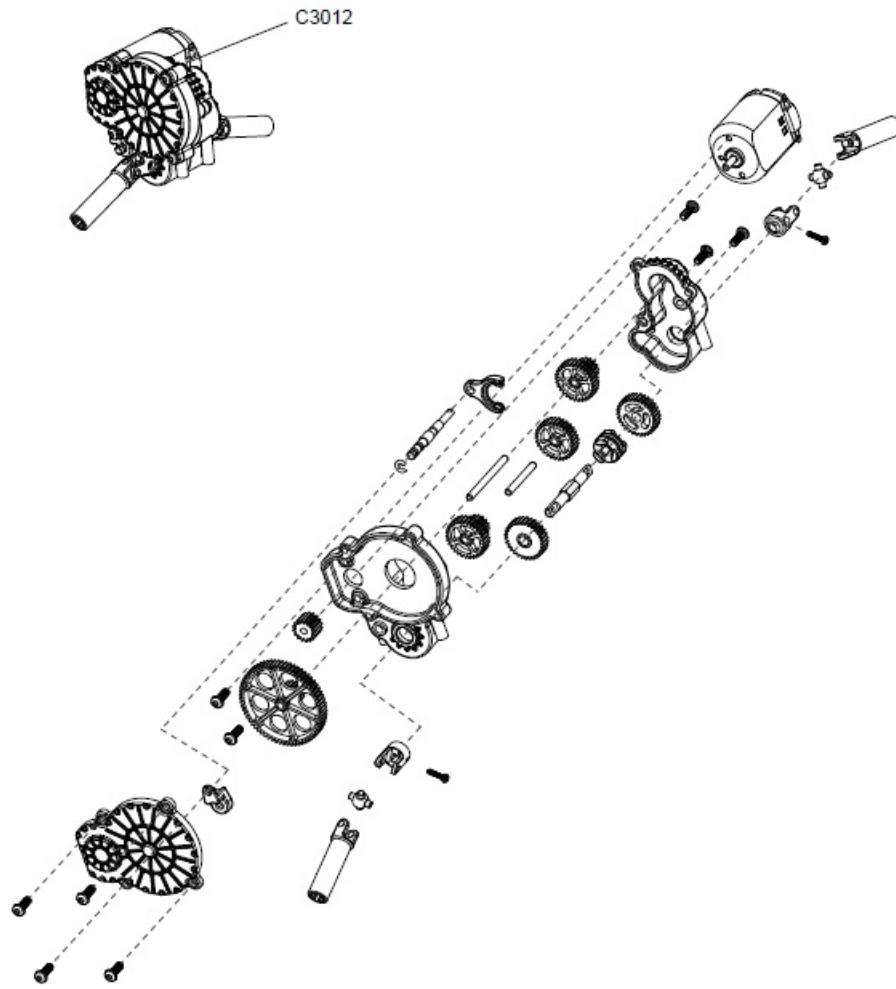

Hard Body Complete Set

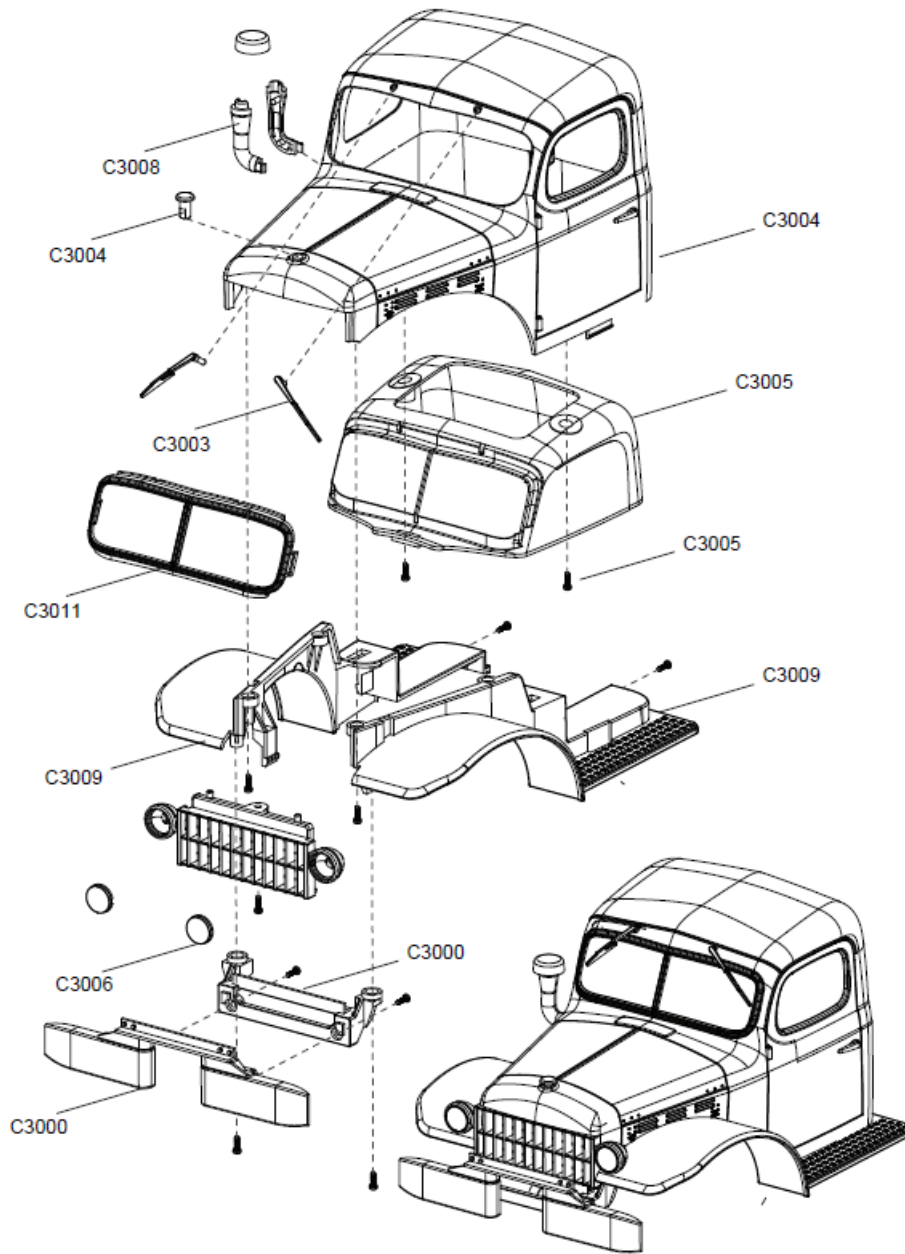

Installation instructions for optional upgrades

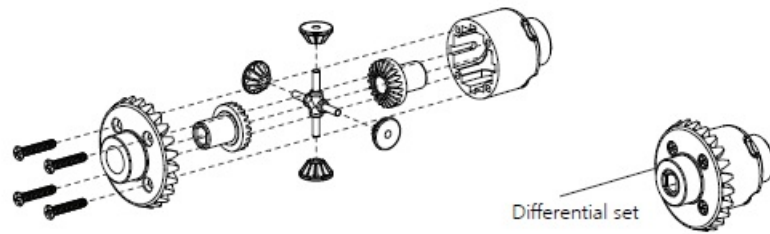

Installation of the differential on the front axle

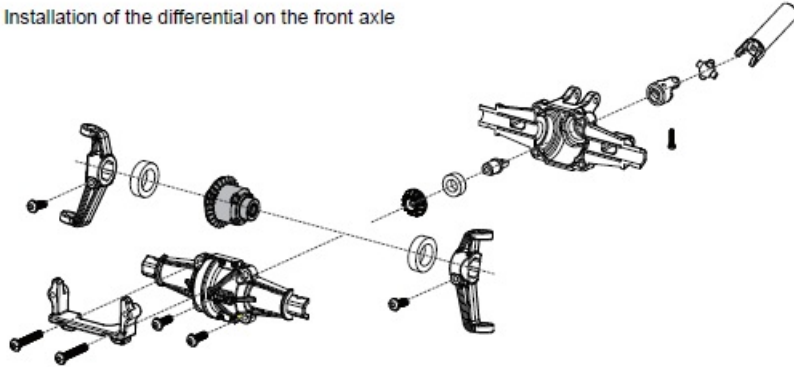

Installation of the differential on the rear axle

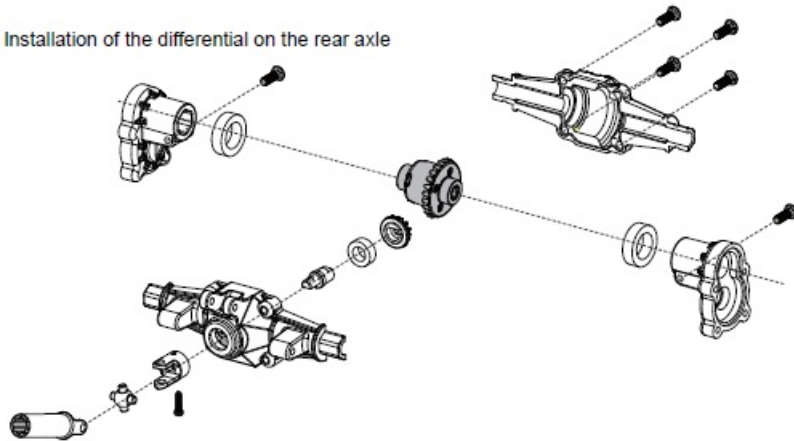

Documents / Resources

	<p>FMS MG41 1:24 FCX24 Power Wagon [pdf] User Manual MG41 1 24 FCX24 Power Wagon, MG41, 1 24 FCX24 Power Wagon, FCX24 Power Wagon, Power Wagon, Wagon</p>
--	---