

SYSTEM FOR CALIBRATION OF SPEAR TRANSPORT LINE TOROIDS*

T. V. Huang, H. Smith and K. Crook
Stanford Linear Accelerator Center
Stanford University, Stanford, California 94305

Summary

A one nanosecond pulse generator has been developed for calibration of the intensity monitors (toroids) in the SPEAR transport lines. The generator, located at the toroid, is simple, low cost and resistant to radiation. This paper describes the generator, and its connection to the standard SLAC toroid calibration system.

Introduction

Calibration of the standard (non-SPEAR) toroids makes use of a single pulse generator (1.6 μ s) in the Main Control Center (MCC). When an operator wants to calibrate a toroid, he sends a pulse of known amplitude on RG-214 cable to the single-turn calibration winding of the selected toroid. The amplitude of the return pulse, as measured at the console, is then set to a standard sensitivity of 100 mV/mA, by adjusting the gain of a distribution amplifier.

In the SPEAR injection beam lines, there are twelve toroids located up to 380 meters from MCC. It is necessary to calibrate these toroids with a 1 ns pulse. If a central pulse generator had been used, the cost of high quality cables would have been prohibitive (approximately \$40,000 for the cable alone). It was therefore decided to install a local generator at each toroid (Fig. 1). The generator uses the principle of discharging an open delay line.



Fig. 1. Local generator—toroid assembly.

Pulse Generator

The generator consists of two lengths of RG-58C coaxial cable and a standard mercury wetted relay with a form C, nonbridging contact. Figure 2 shows the generator with the cover removed. Figure 3 is the schematic of the internal wiring, and the external connections in functional form. A positive or negative dc voltage from the MCC control panel charges the open transmission line L_2 to V_{in} . When the relay is energized, L_2 is connected through the 50 ohm load of the calibrate winding to ground. L_2 acts as a voltage source with an internal impedance of 50 ohms. Consequently, only one-half of the line charging voltage appears

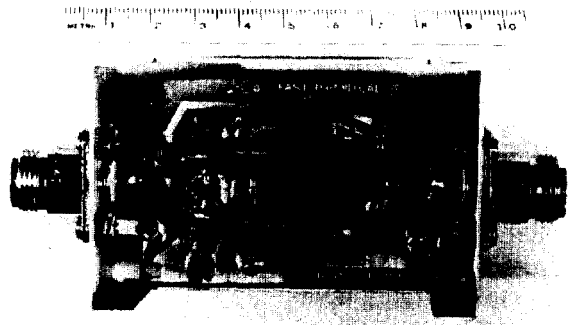

Fig. 2. 1 ns local generator with cover removed.

across the load. This voltage, $V_{in}/2$ is maintained across the load for a period equal to the time it takes for the transient wave to travel to the open end and back. When the relay is de-energized, the contact returns to its normally closed position, connecting L_1 to the load. L_1 , which charged to V_{in} when the relay was energized, now discharges through the load to produce a pulse identical in amplitude and width to that produced by L_2 . Refer to Fig. 4 for timing relationships.

For an ideal line, the width of the pulse is given by

$$\Delta T = 2\ell \sqrt{LC}$$

where ΔT is in seconds, ℓ is the line length in meters, L is the inductance in henries/meter and C is the line capacitance in farads/meter.

For RG58C

$$L = 2.41 \times 10^{-7} \text{ henries/meter}$$

$$C = 9.65 \times 10^{-11} \text{ farads/meter}$$

With regard to cable length versus pulse width, the generator gives reasonable agreement with the ideal case, for pulse widths greater than approximately 5 ns corresponding to a line length of 50.8 cm. However, for pulse widths below this value, noncoaxial wiring within the generator causes deviations from the ideal. For an ideal generator, the coaxial length required for a 1 ns pulse is 10.38 cm. In practice, for this particular wiring geometry, a line length of 2.86 cm is needed.

It can be seen from Fig. 5 that the relationship of $V_{out}/V_{in} = .5$ does not hold for line lengths shorter than 30.5 cm. This is due to internal wiring capacitance which is comparable to the coaxial line capacitance for short cable lengths. The effect of various line lengths on output pulse amplitude is shown in Fig. 6. It can be seen that the 0-100% rise time is approximately 2.5 ns and that a 1 ns pulse rises to only about 65% of the final amplitude. Figure 7 shows the generator output for a 1 ns pulse across at 50 ohm calibrate winding.

Although only one delay line is sufficient to produce the desired pulse, the doubled repetition rate with two delay lines increases the intensity on the oscilloscope display.

System Control

A simplified schematic of the system is shown in Fig. 8. The dc voltage for charging the line is set to the equivalent of 15 mA for electron calibration and 5 mA for positron

*Supported by the Energy Research and Development Admin.

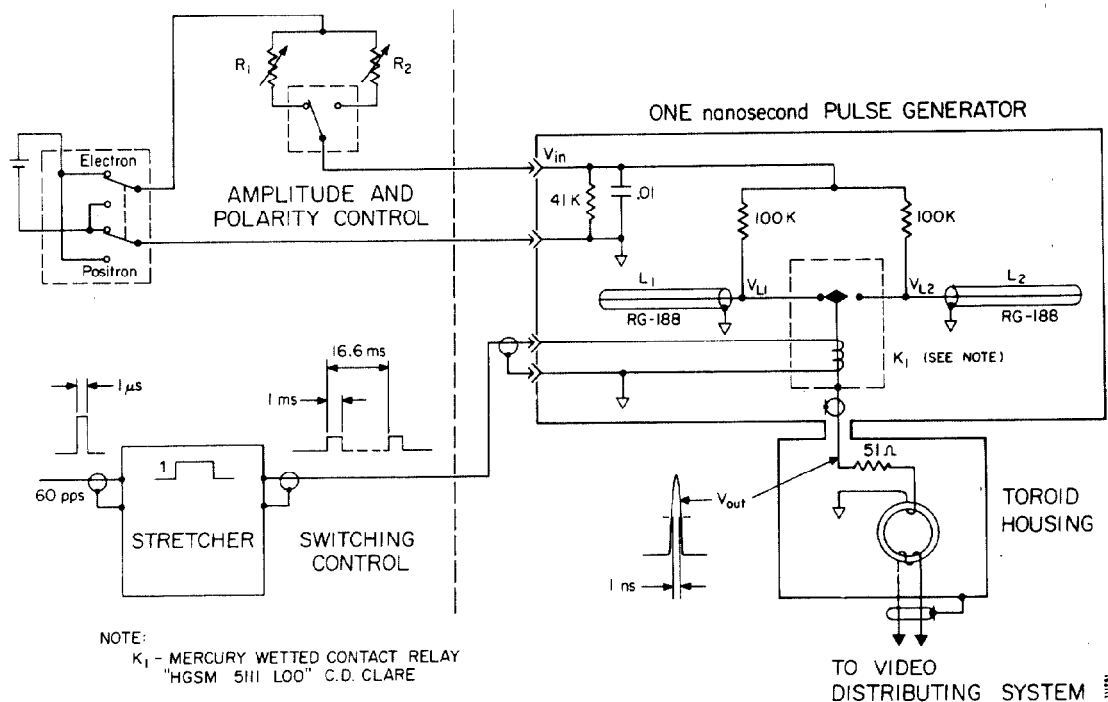

Fig. 3. Generator schematic and functional interconnections.

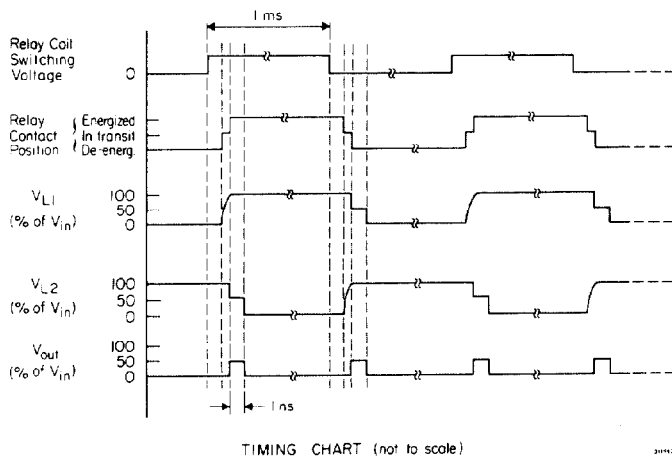

Fig. 4. Timing chart.

calibration. When calibration is desired, polarity selection is made, and the calibrate button is actuated. After a specific toroid is selected, the dc charging voltage is connected to the generator, and a 1 ms pulse at 60 pps is applied to the relay coil in the generator. The return pulse is then viewed on the beam intensity monitor scope, and gain adjustments are made in the video amplifiers, if necessary. It should be noted that the rise time of the complete system—toroids, preamplifiers, cables, distribution amplifiers and viewing scopes—is approximately 30 ns. No attempt has been made to upgrade the components of the system to permit direct viewing of a 1 ns pulse. In fact, there is a fortuitous advantage in viewing a 60–80 ns pulse rather than a 1 ns pulse—namely, that sampling scopes are not required.

Experience

The system described has been in operation for about one year. It permits regular calibration of toroids during our long running cycle (5 months). Previously, calibration was done only during beam down times. This was a

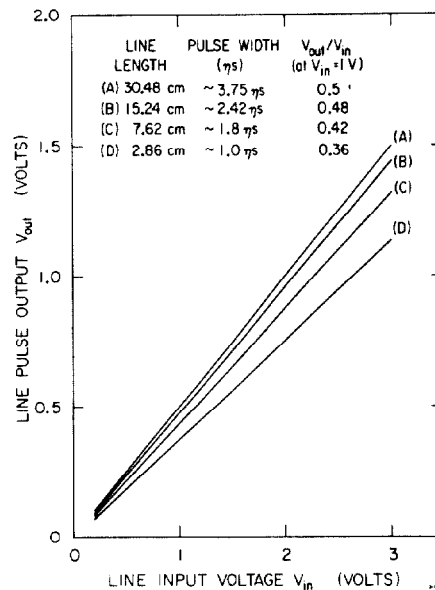

Fig. 5. V_{in} vs. V_{out} for different cable lengths.

cumbersome and lengthy operation, requiring two crews, one with a generator and sampling scope at the toroid, and the other at the control center.

One minor problem is the necessity to go to internal trigger on the viewing oscilloscope when calibrating. This is necessary because even though the 60 pps relay trigger pulse is synchronized to the accelerator triggers, the operate and release times of the relays are variable.

In general, the new generators are a useful tool in the calibration of the SPEAR injection toroids. Optimizing the beam transport through the line is easier when the operator has confidence in the calibration of the intensity monitors.

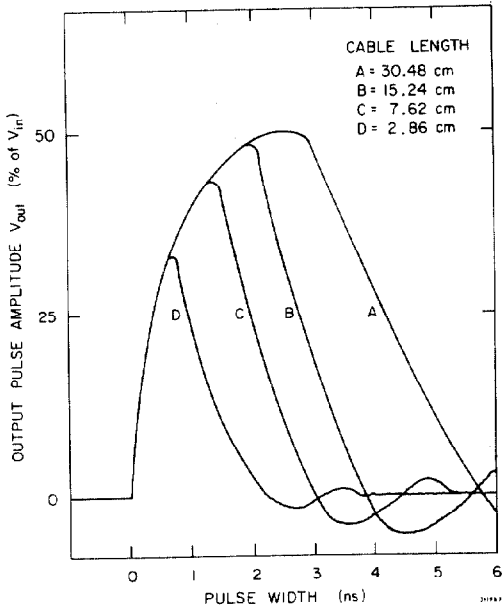

Fig. 6. V_{out} vs. pulse width.

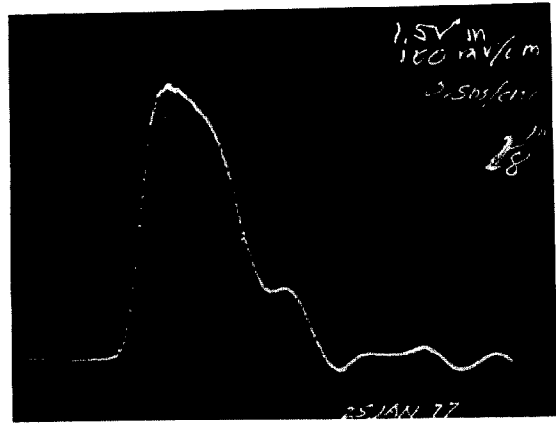

Fig. 7. 1 ns pulse from generator.

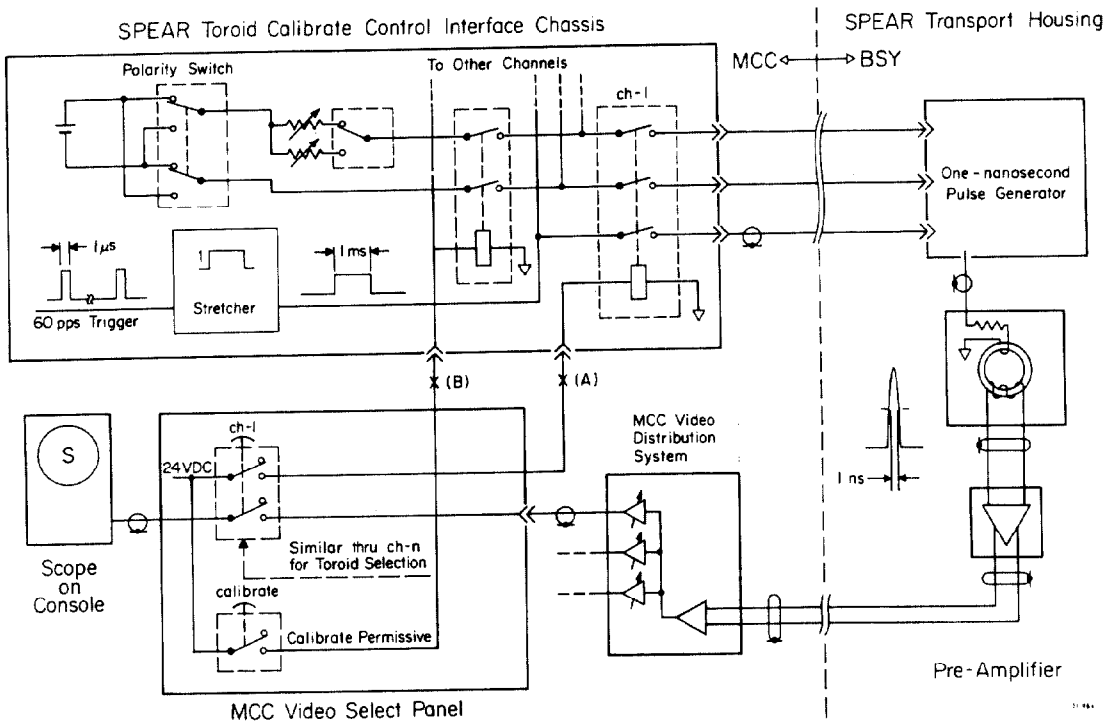

Fig. 8. Toroid calibration system.