



VARIAN 
vacuum technologies

CE

VHS-4, VHS-6 and VHS-250 Diffusion Pumps

INSTRUCTION MANUAL

Part No. 699901024
Revision A
February 2005

VHS-4, VHS-6 and VHS-250 Diffusion Pumps



Warranty

Products manufactured by Seller are warranted against defects in materials and workmanship for twelve (12) months from date of shipment thereof to Customer, and Seller's liability under valid warranty claims is limited, at the option of Seller, to repair, replacement, or refund an equitable portion of the purchase price of the Product. Items expendable in normal use are not covered by this warranty. All warranty replacement or repair of parts shall be limited to equipment malfunctions which, in the sole opinion of Seller, are due or traceable to defects in original materials or workmanship. All obligations of Seller under this warranty shall cease in the event of abuse, accident, alteration, misuse, or neglect of the equipment. In-warranty repaired or replaced parts are warranted only for the remaining unexpired portion of the original warranty period applicable to the repaired or replaced parts. After expiration of the applicable warranty period, Customer shall be charged at the then current prices for parts, labor, and transportation.

When products are used with toxic chemicals, or in an atmosphere that is dangerous to the health of humans, or is environmentally unsafe, it will be the responsibility of the Customer to have the product cleaned by an independent agency skilled and approved in handling and cleaning contaminated materials before the product will be accepted by Vacuum Technologies for repair and/or replacement.

Reasonable care must be used to avoid hazards. Seller expressly disclaims responsibility for loss or damage caused by use of its Products other than in accordance with proper operating procedures.

Except as stated herein, Seller makes no warranty, express or implied (either in fact or by operation of law), statutory or otherwise; and, except as stated herein, Seller shall have no liability under any warranty, express or implied (either in fact or by operation of law), statutory or otherwise. Statements made by any person, including representatives of Seller, which are inconsistent or in conflict with the terms of this warranty shall not be binding upon Seller unless reduced to writing and approved by an officer of Seller.

Disclaimer

Operation and maintenance of this equipment involves serious risk. It is the responsibility of the user to maintain safe operating conditions at all times. Vacuum Technologies assumes no liability for personal injury or damage resulting from operation or service of the equipment.

Vacuum Technologies has no control over the use of this equipment and is not responsible for personal injury or damage resulting from its use. The safe use and disposal of hazardous or potentially hazardous materials of any kind is the sole responsibility of the user. Observe all WARNINGS and CAUTIONS to minimize the serious hazards involved.

It is the sole responsibility of the users of Vacuum Technologies equipment to comply with all local, state and federal safety requirements (laws and regulations) applicable to their system. Employ the services of an industrial hygienist and/or a qualified chemical safety engineer in order to ensure safe installation and use.

Warranty Replacement and Adjustment

All claims under warranty must be made promptly after occurrence of circumstances giving rise thereto, and must be received within the applicable warranty period by Seller or its authorized representative. Such claims should include the Product serial number, the date of shipment, and a full description of the circumstances giving rise to the claim. Before any Products are returned for repair and/or adjustment, written authorization from Seller or its authorized representative for the return and instructions as to how and where these Products should be returned must be obtained. Any Product returned to Seller for examination shall be prepaid via the means of transportation indicated as acceptable by Seller. Seller reserves the right to reject any warranty claim not promptly reported and any warranty claim on any item that has been altered or has been returned by non-acceptable means of transportation. When any Product is returned for examination and inspection, or for any other reason, Customer shall be responsible for all damage resulting from improper packing or handling, and for loss in transit, notwithstanding any defect or non-conformity in the Product. In all cases, Seller has the sole responsibility for determining the cause and nature of failure, and Seller's determination with regard thereto shall be final.

If it is found that Seller's Product has been returned without cause and is still serviceable, Customer will be notified and the Product returned at Customer's expense; in addition, a charge for testing and examination may be made on Products so returned.

3/1/00

This page intentionally left blank.

Declaration of Conformity
Konformitätserklärung
Déclaration de Conformité
Declaración de Conformidad
Verklaring de Overeenstemming
Dichiarazione di Conformità



We
Wir
Nous
Nosotros
Wij
Noi

Varian, Inc.
Vacuum Technologies
121 Hartwell Avenue
Lexington, MA, 02421-3133 USA

declare under our sole responsibility that the product,
erklären, in alleniniger Verantwortung, daß dieses Produkt,
déclarons sous notre seule responsabilité que le produit,
declaramos, bajo nuestra sola responsabilidad, que el producto,
verklaren onder onze verantwoordelijkheid, dat het product,
dichiariamo sotto nostra unica responsabilità, che il prodotto,

VHS-4, VHS-6 and VHS-250 Diffusion Pump

to which this declaration relates is in conformity with the following standard(s) or other normative documents.
auf das sich diese Erklärung bezieht, mit der/den flogenden Norm(en) oder Richtlinie(n) übereinstimmt.
auquel se réfère cette déclaration est conforme à la (auz) norme(s) ou au(x) document(s) normatif(s).
al que se refiere esta declaración es conforme a la(s) norma(s) u otro(s) documento(s) normativo(s).
waamaar deze verklaring verwijst, aan de volende norm(en) of richtlijn(en) beantwoordt.
a cui se riferisce questa dichiarazione è conforme alla/e sequente/I norma/o documento/I normativo/i.

VMF-11	VHS-6	VHS-400	NHS-35
AX-65	VHS-250	HS-16	
AX-150	VHS-4	HS-20	
HS-2	VHS-10	HS-32	

73/023/EEC Low Voltage Directive
EN 61010-1..... "Safety requirements for electrical equipment for measurement, control and laboratory use", incorporating amendments, numbers 1 and 2.

Frederick C. Campbell
Operations Manager
Vacuum Technologies
Varian, Inc.
Lexington, Massachusetts, USA

October 2000



This page intentionally left blank.

Contents

Introduction	1-1
Pump Specifications	1-1
Installation	1-10
Unpacking	1-10
Pump Oil Installation	1-10
Vacuum System Connections	1-11
Cooling Water Connections	1-11
Electrical Connections	1-12
Thermal Switch	1-13
Startup	2-1
Shutdown	2-2
General Maintenance	3-1
Inspection Requirements	3-1
Cleaning	3-2
VHS-4 and VHS-6 Cold Cap Removal/Installation	3-3
VHS-250 Cold Cap Removal/Installation	3-4
Jet Assembly Removal/Installation	3-5
Heater Replacement	3-8
Pump Fluid Charge	3-10
Leakage	4-1
Outgassing	4-1
Poor Pump or System Performance	4-2

This page intentionally left blank.

Figures

1-1	VHS-4 Speed and Throughput Curves	1-4
1-2	VHS-4 Wiring Information	1-4
1-3	VHS-6 Speed and Throughput Curves	1-6
1-4	VHS-6 Wiring Information	1-6
1-5	VHS-250 Speed and Throughput Curves	1-8
1-6	VHS-250 Wiring Information	1-8
3-1	VHS4 and VHS-6 Cold Cap Removal/Installation	3-3
3-2	VHS-250 Cold Cap Removal/Installation.....	3-4
3-3	VHS-4 Diffusion Pump Jet Assembly	3-6
3-4	VHS-6 and 250 Diffusion Pump Jet Assembly	3-7
3-5	VHS-6 and VHS-250 Heater Mounting	3-8
3-6	VHS-4 Heater Mounting	3-9

This page intentionally left blank.

Tables

1-1	Pump Operational Specifications	1-1
1-2	VHS-4 Dimensions	1-5
1-3	VHS-6 Dimensions	1-7
1-4	VHS-250 Dimensions	1-9
4-1	Troubleshooting.....	4-2
5-1	VHS-4 Models	5-1
5-2	VHS-4 Replacement Parts	5-1
5-3	VHS-6 Models	5-2
5-4	VHS-6 Replacement Parts	5-3
5-5	VHS-250 Models	5-4
5-6	VHS-250 Replacement Parts	5-4

This page intentionally left blank.

Preface

Instructions for Use

This equipment is designed for use by professionals. Read this instruction manual and any other additional information supplied by Vacuum Technologies before operating the equipment. Vacuum Technologies will not be held responsible for any events that occur due to non-compliance with these instructions, improper use by untrained persons, non-authorized interference with the equipment, or any action contrary to that provided for by specific national standards.

Documentation Standards

This manual uses the following documentation standards:

WARNING



Warnings are for attracting the attention of the operator to a particular procedure or practice which, if not followed correctly, could lead to serious injury.

CAUTION



Cautions are displayed before procedures, which if not followed, could cause damage to the equipment.

NOTE



Notes contain important information.

Safety

Diffusion Pump Hazards

Designers of systems utilizing diffusion pumps must design out hazards wherever possible. For hazards that cannot be designed out, warnings, procedures, and instructions on proper use and servicing are provided. Please use guards, safety features, and interlocks as recommended.

Refer to the following tables for a list of general hazards and recommended actions, a list of prohibited actions that can result in explosions, and a list of pressurization hazards that can result in damage to equipment.

THE INSTALLATION, OPERATION, AND SERVICING OF DIFFUSION PUMPS INVOLVES ONE OR MORE OF THE HAZARDS LISTED IN THIS SECTION, ANY ONE OF WHICH IN THE ABSENCE OF SAFE OPERATING PRACTICES AND PRECAUTIONS, COULD POTENTIALLY RESULT IN DEATH OR SERIOUS HARM TO PERSONNEL.

VHS-4, VHS-6 and VHS-250 Diffusion Pumps

General Hazards

Hazard	Suggested Corrective Action
Loss of utility: water and/or electricity	Provide sufficient backup water and power supply as necessary to effect a safe shutdown under worst case conditions.
Overpressure in foreline	Provide an interlock to ensure that the power supply to the pump heater cannot be activated if the foreline pump is not running and/or the pressure in foreline is above 0.5 Torr (0.67 mbar).
Overtemperature	Fit temperature sensors and pump fluid level sensors with feedback to an interlock on the heater power supply.
Insufficient water flow through main cooling coils	Use water flow sensor and feedback to interlock the heater power supply.
Water trapped between inlet and outlet of Quick Cool Coil, or liquid nitrogen trapped between inlet and outlet of liquid nitrogen trap	Provide vent or pressure relief valves for both Quick Cool Coil and liquid nitrogen trap.
Loss of electrical ground integrity	Incorporate ground fault interrupt circuit into heater power supply.
Positive pressure in pumping system	Integrate pressure relief valve in vacuum system.
High voltage	Prevent personnel contact with high voltages; design and attach warnings.
Toxicity and Corrosivity	Toxic and/or corrosive gases must be vented to a safe location, ensuring adequate dilution or scrubbing to safe levels, taking all action required to meet air quality standards.
Explosion	Integrate pressure relief valves in all systems using pumps 10" or larger in diameter. Do not use hydrocarbon-based pumping oils.

Explosion

Operation of the diffusion pump without continuous evacuation below 0.5 Torr (0.67 mbar) or without coolant, and then introducing a strong oxidizer (such as air), explosive vapors, powders, or materials which may react with pumping fluids in a *hot* pump (above 300 °F or 150 °C) can cause an explosion. Such an explosion would violently expel valves and other hardware, slam open doors that are not designed for appropriate pressure relief, or burst other components of the vacuum system. Serious injury or death could result from expelled parts, doors, shrapnel, and shock waves.

Avoid the implementing the following three elements that could result in an explosion:

- Fuel
- Oxidizer
- Ignition

A combination of temperature and pressure can be a source of ignition. Most diffusion pump fluids, except mercury, are fuels. Hydrocarbon oils are more prone to oxidize and explode than synthetic silicone-based oil. The oxidizer can be air, which is a strong oxidizer that is introduced by a leak, deliberately brought in via a process, or inadvertently admitted by an operator or by a process controller error.

Explosion and Fire from Acetone and Alcohol

Diffusion pumps are typically cleaned with acetone and alcohol. When combined with air, oxygen, and other oxides, alcohol and most other solvents are very flammable and explosive. Never permit any trace of these cleaners to remain in or on the pump. Remove all traces of alcohol and acetone and other cleaners with clean, dry, oil-free compressed air.

Oxygen and other strong oxidizers are even more dangerous than air. Certain conditions of temperature and pressure can cause a combustible mixture to explode. The larger the diffusion pump, the greater the risk of explosion and the greater the risk of damage and injury. Never operate large diffusion pumps utilizing hydrocarbon oils without a complete safety analysis for the entire system and for the application.

Never operate a large diffusion pump under the conditions listed in the following table. Any of these situations increases the probability of an explosion.

VHS-4, VHS-6 and VHS-250 Diffusion Pumps

Explosive Conditions

Prohibited Action	Explosion-Causing Condition
Do not run pump without cooling water.	Overtemperature
Do not run pump with low level of pump fluid.	Overtemperature
Do not run pump without proper backing or holding pump.	Overpressure
Do not run pump when not evacuated below 0.5 Torr (0.67 mbar).	Overpressure
Do not admit air to, or rough through, a pump with hot boiler.	Overpressure plus strong oxidizer
Do not open drain or fill plug while pump is under vacuum, especially when it is hot.	Overpressure plus strong oxidizer
Do not contaminate pump with explosive vapors.	Lower explosive threshold of gas mixtures
Do not remove, defeat, or override safety counter-measures such as pressure and thermal switches and valve sequencer interlocks.	Overtemperature, overpressure, more combustible mixtures
Do not machine or weld any part of the pump without removing all oil or solvent residue in pump in large pumps.	Source of ignition
Do not use unsuitable pumping fluid, especially hydrocarbon oil.	Lower explosive threshold of gas mixture

VHS-4, VHS-6 and VHS-250 Diffusion Pumps

Pressurization Hazards

Large vacuum pumps and their components are designed for vacuum service. They are not designed to be pressurized, which can cause them to burst and possibly expel shrapnel at lethal velocities. Serious accidents have been caused by intentional pressurization of vacuum systems and their components.

- ❑ Never pressurize any part of a vacuum system for test or any other purpose.
- ❑ Always provide pressure relief when designing diffusion pumps into systems and ensure that pressure relief motion is limited to safe envelopes.
- ❑ Never permit any of the hazards in the table below to develop.

Pressurization Hazards

Prohibited Action	Result
Do not block inlet or vent of liquid nitrogen trap and lines.	LN ₂ trap and/or lines burst
Do not close isolation valves at inlet and discharge of main water cooling coils when pump is reheated.	Water turns to steam and bursts coils
Do not pressurize the pump body.	Body of pump bursts
Do not make a hole through the vacuum wall.	Loss of structural integrity of wall

Pressure Relief Devices

Systems larger than 10", such as this pump, must be designed with pressure relief devices to provide safe pressure relief from internal explosions. Always recognize that safety devices can fail or malfunction; provide redundant protection by installing devices having different failure modes, failure mechanisms, and failure causes. Be certain that exhaust duct materials are capable of withstanding the corrosivity, temperature, and pressure of exhausted products.

Dangerous Substances

Chemical Dangers of Acetone and Alcohol

Diffusion pumps are typically cleaned with acetone or alcohol. Acetone, alcohol, and most other solvents are irritants, narcotics, and depressants, and/or carcinogenic. Their inhalation and ingestion may produce serious effects. Even absorption through the skin can result in moderate toxicity.

Ensure that cleaning operations are always performed in large, well-ventilated rooms. The use of a self-contained breathing apparatus may be necessary depending upon the solvent type and vapor concentration in surrounding air.

Poisonous and Corrosive Compounds

When pumping poisonous, reactive, and/or corrosive gas, vapors, or chemicals, proper operation and regeneration do not always ensure that all hazardous materials have been totally removed.

If hazardous gas, vapors, chemicals, or combustible mixtures are pumped, sufficient quantities may exist during operation or remain after regeneration to cause severe injury or death.

Pump Fluids

Overheating the pump fluid, exposing it to air or reactive materials, or overpressurizing it above the normal operating range (approximately 1×10^{-3} Torr / 1.3×10^{-3} mbar) decomposes the fluid and possibly makes it toxic. This is especially true of backstreamed mechanical pump oils which are more volatile (unstable). Overheating of accidentally introduced or backstreamed mechanical pump oils cannot be protected against by thermal switches which are set for diffusion pump oil.

Process Gasses

These gasses are frequently toxic, flammable, corrosive, explosive, or otherwise reactive. Vacuum Technologies has no control over the types of gasses passing through your diffusion pump as these are entirely under the control of the process user and/or the hardware systems integrator. Since these gasses can cause serious injury or death, it is very important to plumb the exhaust of the pump to the facility's hazardous gas exhaust system which incorporates appropriate filters, scrubbers and similar components to ensure that the exhaust meets all air and water pollution control regulations.

High Temperatures

Hot Surfaces

Boiler temperatures reach 530 °F (275 °C) which can cause serious burns. Always ensure that surfaces have cooled to near room temperature before touching them.

Hot Cooling Water and Steam

The water used to cool the pump can reach scalding temperatures. Touching or rupturing the cooling surface can cause serious burns. Water left inside Quick Cool Coils from previous use turns to steam when the pump is reheated. This steam must be allowed to escape without coming into contact with personnel. Whenever possible, design the water system with interlock valves so that power cannot be applied to the pump unless water is flowing in the main cooling coils (not the Quick Cool Coils).

High Voltages

Diffusion pump heaters operate at voltages high enough to kill. Design systems to prevent personnel contact with high voltages. Securely attach prominent hazard warnings. Always break the primary circuit to the power supply when direct access to the heater or wiring is required.

Section 1. Introduction and Installation

1.1 Introduction

Before unpacking and installing a VHS-4, VHS-6 or VHS-250 diffusion pump, thoroughly familiarize yourself with this instruction manual and the diffusion pump operational specifications (Table 1-1). Examine all other technical material supplied in order to gain a better understanding of the operating principles, limitations, correct application, and hazards involved with the operation of this equipment.

1.1.1 Pump Specifications

Table 1-1 lists the specifications for the VHS-4, VHS-6 and VHS-250 pumps.

Table 1-1 Pump Operational Specifications

Power Rating	VHS-4: 1450 Watts VHS-6: 2200 Watts VHS-250: 2200 Watts
Optimum Operating Range (Torr)	VHS-4 and VHS-6: 1×10^{-3} to $< 5 \times 10^{-9}$ (1.3×10^{-3} to $< 6.6 \times 10^{-9}$ mbars) VHS-250: 7×10^{-4} to $< 5 \times 10^{-9}$ (9×10^{-4} to $< 6 \times 10^{-9}$ mbars)
Maximum Pumping Speed (l/s)	VHS-4: Air – 1200 with std cold cap; 950 with extended cold cap Helium –1500 with std cold cap; 1200 with extended cold cap VHS-6: Air – 2400 with std cold cap; 1600 with extended cold cap Helium –3000 with std cold cap; 2000 with extended cold cap VHS-250: Air – 3700 with std cold cap; Helium –4600
Maximum Throughput (Torr-l/s)	VHS-4: 1.2 (1.6 mbar-l/s) in operating range 2.5 (3.2 mbar-l/s) @0.01 Torr VHS-6: 2.4 (3.2 mbar-l/s) in operating range 3.5 (4.5 mbar-l/s) @0.01 Torr VHS-250: 2.6 (3.5 mbar-l/s) in operating range 3.5 (4.5 mbar-l/s) @0.01 Torr
Maximum Forepressure	No Load – 0.65 Torr (.87 mbars) Full Load – 0.55 Torr (.73 mbars)

VHS-4, VHS-6 and VHS-250 Diffusion Pumps

Table 1-1 Pump Operational Specifications (Continued)

Backstreaming Rate at Pump Inlet	5×10^{-4} mg/cm ² /minute (with std cold cap)
Electrical Requirements	120, 208, 240; 50/60 Hz; single phase
Warm-up Time	10 minutes
Cooldown Time (using Quick Cool Coil)	10 minutes
Fluid Charge	VHS-4: 300 cc VHS-6 and VHS-250: 500 cc
Cooling Water Requirements	Maximum inlet temperature – 60/80 °F (15 - 26 °C) Maximum outlet temperature at foreline – 120 °F (48.9 °C) Flow rate – VHS-4: 0.15 gpm VHS-6 and VHS-250: 0.25 gpm
Pressure drop across coils	VHS-4: 4 psi VHS-6 and VHS-250: 15 psi
Backing Pump Size	VHS-4: ≥ 10 cfm for maximum throughput VHS-6 and VHS-250: 17 cfm for maximum throughput
Recommended Jet Assembly	4-stage, self-aligning, stainless steel
Foreline Baffle	Stacked half moon
Cold Cap	Nickel-plated copper
Water Connections	1/8" FPT
Thermal Switches	Manual reset at 300 °F

VHS-4, VHS-6 and VHS-250 Diffusion Pumps

Table 1-1 Pump Operational Specifications (Continued)

Heater circuit resistance (ohms)	VHS-4: 1450 watts 120 V – 10 208 V – 29.8 240 V – 39.7 VHS-6 and VHS-250: 2200 watts 120 V – 6.5 208 V – 19.6 240 V – 26.1
Clearance (for heater removal)	6" minimum
Materials	Body, Flanges, Foreline, Baffle – stainless steel Jet Assembly – stainless steel Body Cooling Coils – copper Quick Cooling Coil – stainless steel Cold Cap – nickel-plated copper
Shipping Weight	VHS-4: 55 pounds VHS-6 and VHS-250: 75 pounds

VHS-4, VHS-6 and VHS-250 Diffusion Pumps

Figure 1-1 shows the VHS-4 speed and throughput curves.

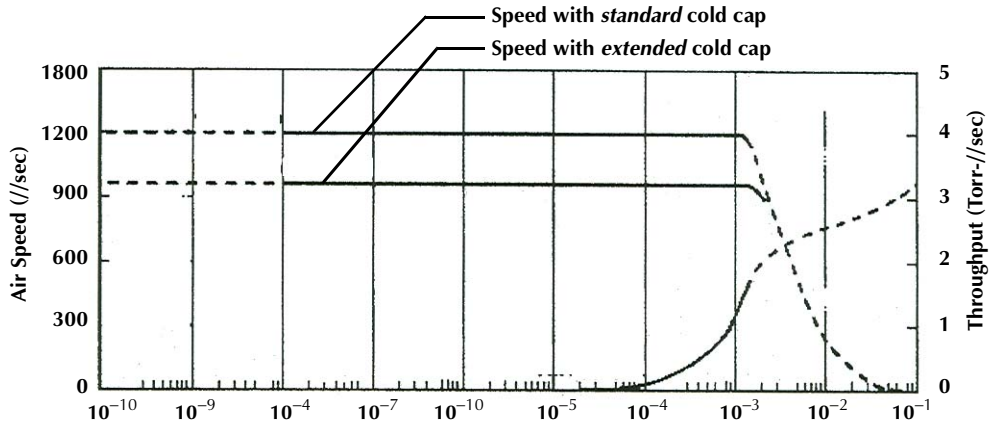

INLET PRESSURE — TORR

*Note: Speed curves were generated according to AVS Standards 4.1

Figure 1-1 VHS-4 Speed and Throughput Curves

NOTE



Speed curves were generated according to AVS Standard 4.1.

Figure 1-2 gives the VHS-4 wiring information.

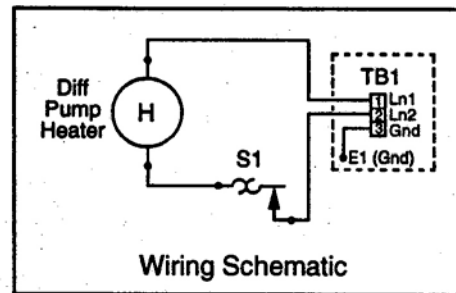
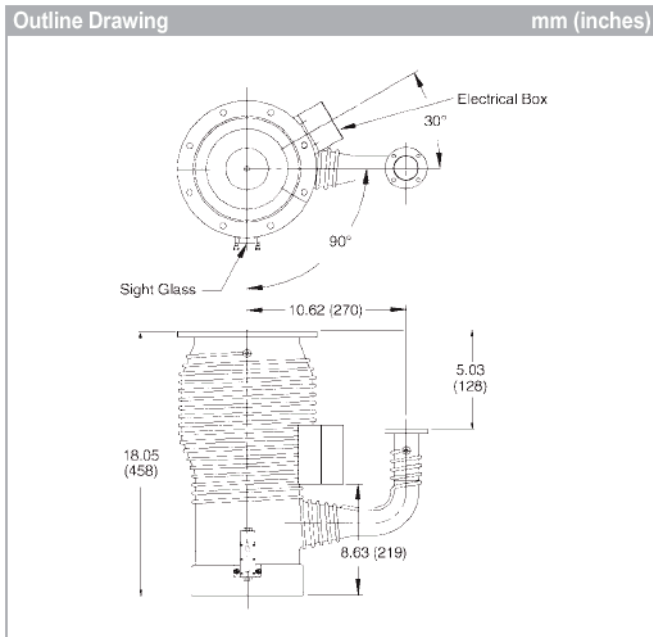

Figure 1-2 VHS-4 Wiring Information

VHS-4, VHS-6 and VHS-250 Diffusion Pumps

Table 1-2 lists the VHS-4 dimensions.

Table 1-2 VHS-4 Dimensions

	ASA		ISO		Conflat	
	in	mm	in	mm	in	mm
Height	18.05	458	18.05	458	18.05	458
Centerline to Centerline	10.62	270	10.62	270	10.62	270
Flange Face to Flange Face	5.03	128	5.03	128	5.03	128
Electrical Box Height	8.63	219	8.63	219	8.63	219
Sight Glass, Degrees from Foreline	90° clockwise		90° clockwise		90° clockwise	
Electrical Box, Degrees from Foreline	30° counterclockwise		30° counterclockwise		30° counterclockwise	
Inlet Flange, Nominal Size	4" ASA		ISO -160K		8" CFF	
Inlet Flange, OD	9.00	229	7.09	180	7.96	202
Inlet Flange, ID	5.91	150	5.78	147	5.91	150
Inlet Flange, Thickness	0.50	13	0.47	12	0.93	24
Inlet Flange, Bolt Circle	7.50	191	N/A	N/A	7.12	181
Inlet Flange, Number of Holes	8		N/A		20	
Inlet Range, Hole Size	0.69	18	N/A	N/A	.33	8
O-ring Groove ID	6.06	154	N/A	N/A	N/A	N/A
O-ring Groove Width	0.18	4	N/A	N/A	N/A	N/A
Foreline Flange, Nominal Size	KF40		KF-40		2 ³ / ₄ CFF	
OD	2.16	55	2.16	55	2.73	69
ID	1.38	35	1.38	35	1.38	35
Thickness	0.20	5	0.20	5	1.38	35
Bolt Circle	N/A	N/A	N/A	N/A	2.31	59
Number of Holes	N/A	N/A	N/A	N/A	6	
Hole Size	N/A	N/A	N/A	N/A	0.27	7
O-ring Groove ID	N/A	N/A	N/A	N/A	N/A	N/A
O-ring Groove Width	N/A	N/A	N/A	N/A	N/A	N/A

VHS-4, VHS-6 and VHS-250 Diffusion Pumps

Figure 1-3 shows the VHS-6 speed and throughput curves.

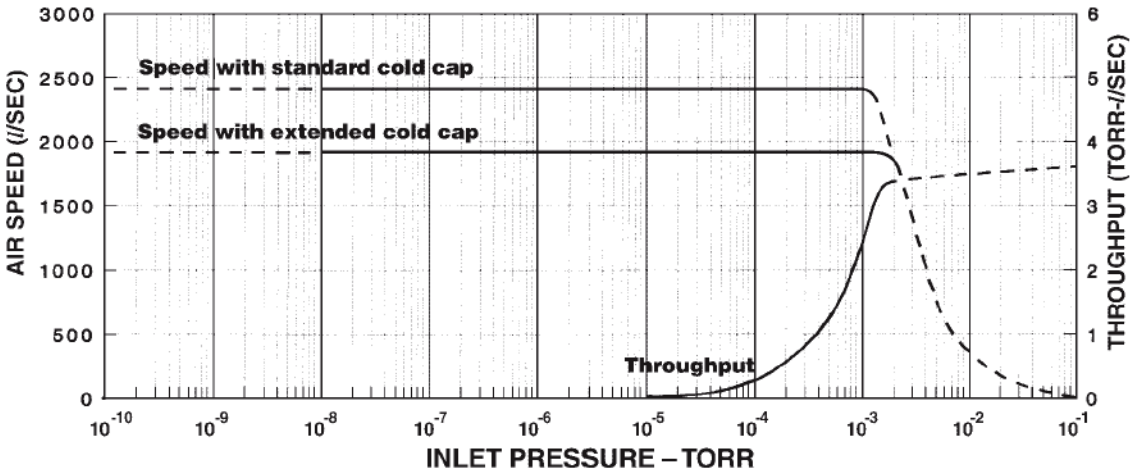

Figure 1-3 VHS-6 Speed and Throughput Curves

Figure 1-4 gives the VHS-6 schematic and wiring information.

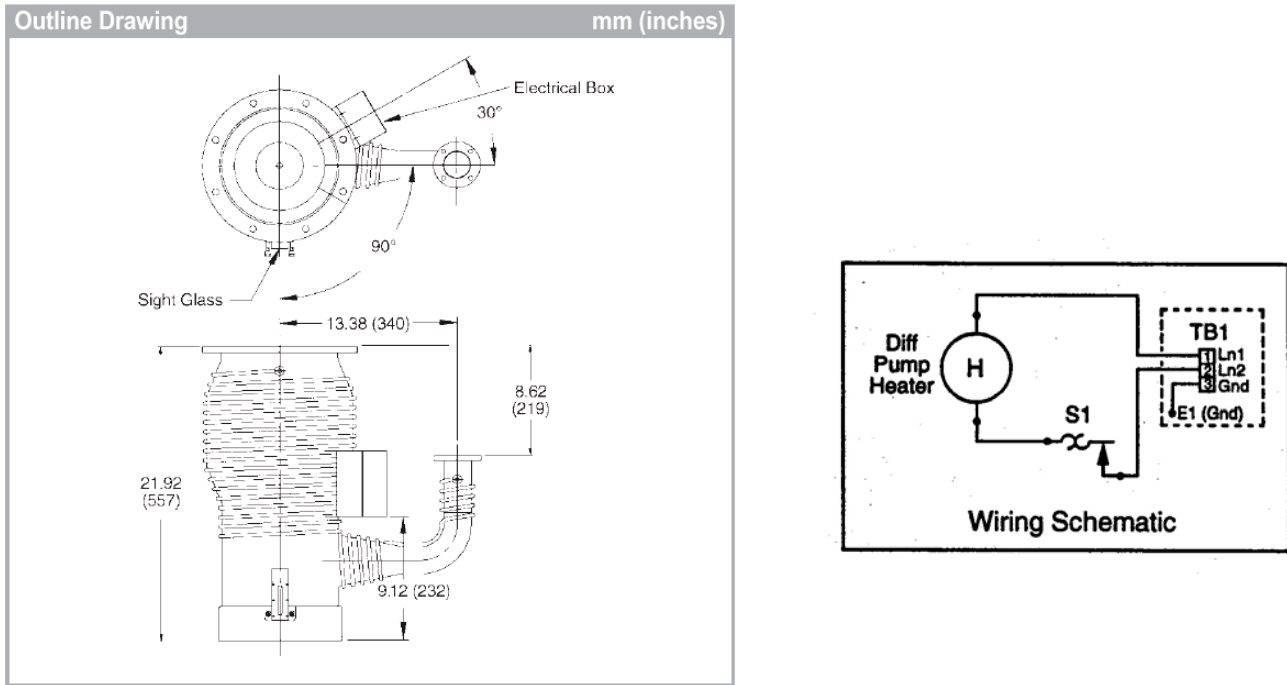

Figure 1-4 VHS-6 Wiring Information

VHS-4, VHS-6 and VHS-250 Diffusion Pumps

Table 1-3 lists the VHS-6 dimensions.

Table 1-3 VHS-6 Dimensions

	ASA		ISO		Conflat	
	in	mm	in	mm	in	mm
Height	21.92	557	21.92	557	21.92	557
Centerline to Centerline	13.38	340	13.38	340	13.38	340
Flange Face to Flange Face	8.62	219	8.62	219	8.62	219
Electrical Box Height	9.12	232	9.12	232	9.12	232
Sight Glass, Degrees from Foreline	90° clockwise		90° clockwise		90° clockwise	
Electrical Box, Degrees from Foreline	30° counterclockwise		30° counterclockwise		30° counterclockwise	
Inlet Flange, Nominal Size	6" ASA		ISO -200K		10" CFF	
Inlet Flange, OD	11.00	279	9.45	240	9.97	253
Inlet Flange, ID	7.88	200	7.72	196	7.88	200
Inlet Flange, Thickness	0.75	19	0.47	12	0.96	24
Inlet Flange, Bolt Circle	9.50	241	N/A	N/A	9.12	232
Inlet Flange, Number of Holes	8		N/A		24	
Inlet Range, Hole Size	0.81	21	N/A	N/A	.33	8
O-ring Groove ID	8.20	208	N/A	N/A	N/A	N/A
O-ring Groove Width	0.18	4	N/A	N/A	N/A	N/A
Foreline Flange, Nominal Size	1½" ASA		KF-50		33/8" CFF	
OD	5.00	127	2.05	75	3.38	86
ID	1.95	50	1.95	50	1.95	50
Thickness	0.63	16	0.24	6	0.62	16
Bolt Circle	3.88	99	N/A	N/A	2.85	72
Number of Holes	4		N/A	N/A	8	
Hole Size	0.62	16	N/A	N/A	0.33	8
O-ring Groove ID	2.22	56	N/A	N/A	N/A	N/A
O-ring Groove Width	0.30	8	N/A	N/A	N/A	N/A

VHS-4, VHS-6 and VHS-250 Diffusion Pumps

Figure 1-5 shows the VHS-250 speed and throughput curves.

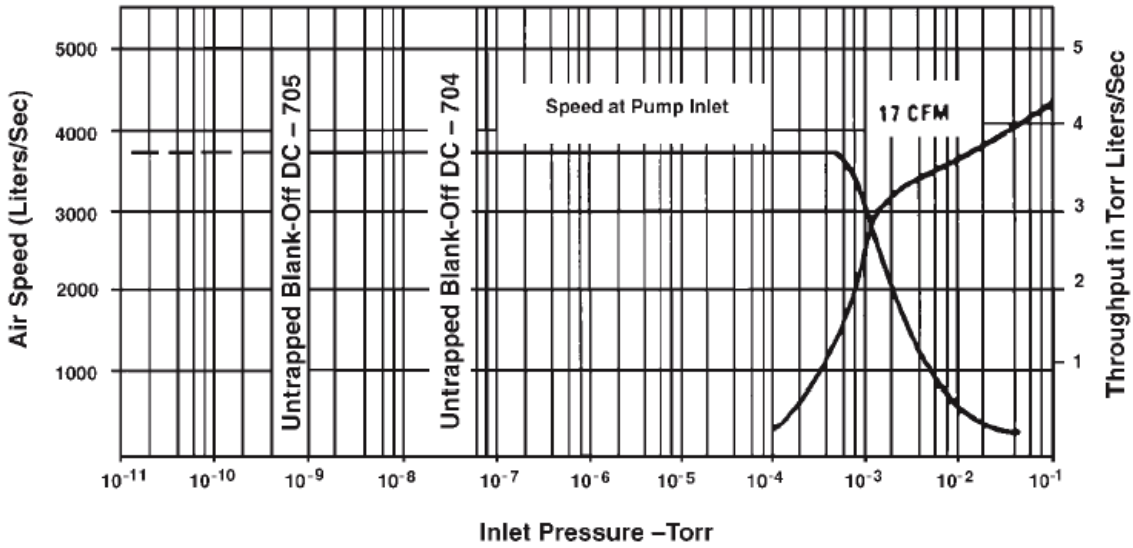

Figure 1-5 VHS-250 Speed and Throughput Curves

Figure 1-6 gives the VHS-250 schematic and wiring information.

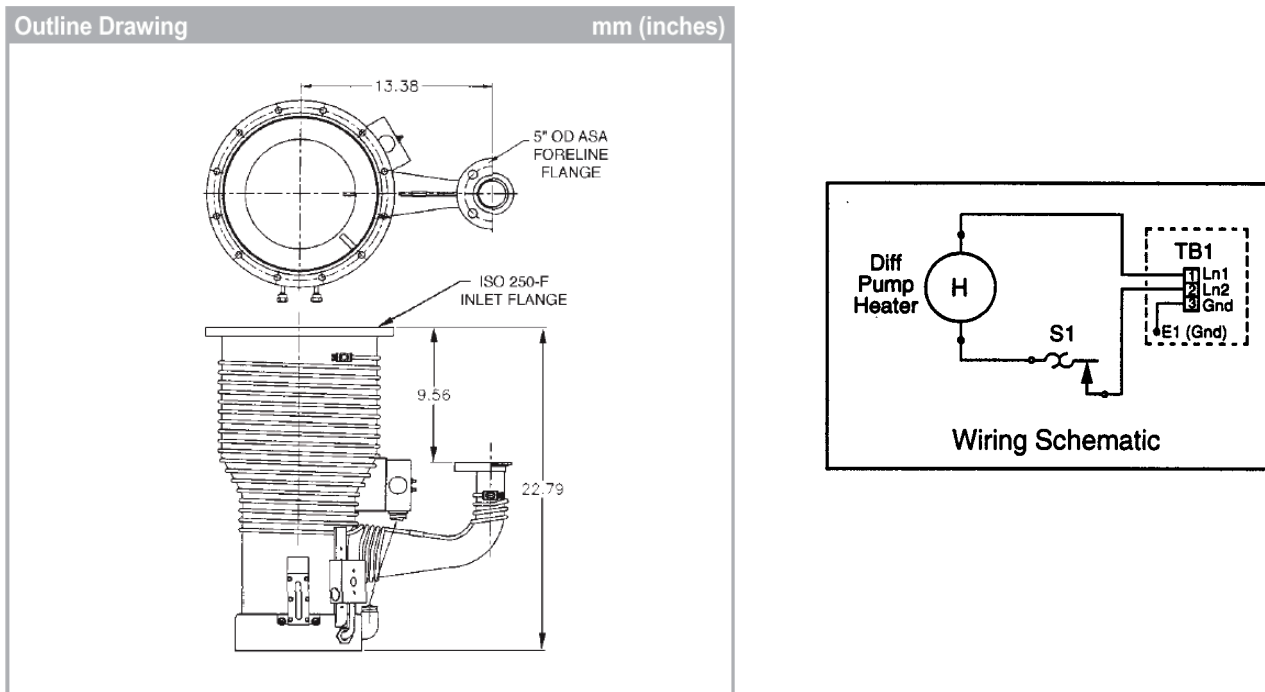

Figure 1-6 VHS-250 Wiring Information

VHS-4, VHS-6 and VHS-250 Diffusion Pumps

Table 1-4 lists the VHS-250 dimensions.

Table 1-4 VHS-250 Dimensions

	ISO	
	in	mm
Height	22.79	579
Centerline to Centerline	13.38	340
Flange Face to Flange Face	9.56	243
Electrical Box Height	9.12	232
Sight Glass, Degrees from Foreline	90° clockwise	
Electrical Box, Degrees from Foreline	30° counterclockwise	
Inlet Flange, Nominal Size	ISO - 250F	
Inlet Flange, OD	13.19	335
Inlet Flange, ID	10.75	273
Inlet Flange, Thickness	0.63	16
Inlet Flange, Bolt Circle	12.205	310
Inlet Flange, Number of Holes	12	
Inlet Range, Hole Size	0.44	11
O-ring Groove ID	10.95	278
O-ring Groove Width	0.14	4
Foreline Flange, Nominal Size	1 ½ ASA	
OD	5.00	127
ID	1.88	48
Thickness	0.62	16
Bolt Circle	3.88	99
Number of Holes	4	
Hole Size	0.62	16
O-ring Groove ID	2.22	56
O-ring Groove Width	0.30	8

1.2 Installation

Installation consists of:

- ❑ Section 1.2.2 “Unpacking”
- ❑ Section 1.2.3 “Pump Oil Installation”
- ❑ Section 1.2.4 “Vacuum System Connections” on page 1-11
- ❑ Section 1.2.5 “Cooling Water Connections” on page 1-11
- ❑ Section 1.2.6 “Electrical Connections” on page 1-12
- ❑ Section 1.2.7 “Thermal Switch” on page 1-13

1.2.2 Unpacking

When unpacking the pump:

1. Inspect the pump to ensure that no damage has occurred during shipping.

Do not discard any evidence of rough handling; report any damage to the carrier and to Vacuum Technologies without delay.

Diffusion pumps are factory-packed to permit prolonged storage in suitably protected areas without special precautions.

2. Remove flange covers and protective plugs from water connections being careful not to scratch the inlet and foreline flanges O-ring seal surfaces.
3. Inspect the internal jet assembly. It should be concentric and firmly seated on the bottom of the diffusion pump and the ejector nozzle must be directly in line with the foreline.

The location of the jet is controlled by an indexing pin located on the bottom of the pump.



The pump requires no initial cleaning if the required vacuum level is above 10^{-6} Torr. For pressure below 10^{-6} Torr (1.3×10^{-6} mbar), follow the cleaning procedure in Section 3.3 “Cleaning” on page 3-2.

4. Charge the pump with the diffusion pump oil shipped with the pump.

1.2.3 Pump Oil Installation

The recommended oil charge for the:

- ❑ VHS-4 is 300 cc
- ❑ VHS-6 and VHS-250 is 500 cc
- ❑ Pour the oil is normally into the pump inlet or foreline, or remove the fill plug and pour it into the fill and drain assembly.

1.2.4 Vacuum System Connections

WARNING



*Utility failure can cause damage to the equipment, overheating, and explosions. Diffusion pump equipment designers must take appropriate system design action to protect personnel and property from possible hazards. **Read the safety section at the beginning of this manual.***

1. Install the diffusion pump with the body vertical and plumb.
2. Ensure that the pump inlet mating flange on the system is horizontal within $\pm 1^\circ$. The boiler plate must be horizontal to prevent an uneven fluid level.

CAUTION



Failure to meet this requirement could result in overheating of the diffusion pump boiler plate.

3. Prepare the inlet and foreline O-rings by wiping them with a clean, lint-free cloth. A small amount of diffusion pump oil may be used to clean the O-rings.
4. Install the O-rings in the O-ring grooves, being careful not to damage or scratch the sealing surface.
5. Check the fill and drain plugs for tightness and apply light to medium torque, enough to compress the O-rings.
6. Using an appropriate lifting apparatus, align the bolt holes of the inlet flange with the bolt holes of the mating flange.
7. Using the appropriate mounting hardware, tighten the bolts evenly until the O-ring is compressed and the flanges make light, metal-to-metal contact.
8. Ensure the integrity of the connections: Check the vacuum connections for leaks using a helium mass spectrometer leak detector before operating the vacuum system.

1.2.5 Cooling Water Connections

1. Connect the inlet water fitting (near the inlet flange at the top of the pump) to a continuously running water supply at 0.15 gpm (VHS-4) or .25 gpm (VHS-6 and 250) and at a temperature of 60 to 80 °F.

CAUTION



In the following step, discharge connections must be installed in accordance with all Federal State and local laws and regulations.

If the diffusion pump is being cooled by a recirculating water system:

- Ensure the exit water temperature does not exceed 120 °F.*
- The outlet or discharge (nearest the foreline) should be connected to an open drain.*

VHS-4, VHS-6 and VHS-250 Diffusion Pumps

- The minimum rating of this system should be 85% of the maximum power rating of the diffusion pump.*
 - The Quick Cool Coil feed line, located at the boiler plate, should be controlled by a separate three-way valve (open, closed, and vent to atmosphere).*
2. Connect the quick cool drain to an open drain which is below the inlet connection of the Quick Cool Coil to ensure that the Quick Cool Coil is completely drained when the cooling water supply is turned off and the pump is vented to atmosphere.

1.2.6 Electrical Connections

WARNING



Diffusion pump heaters operate at voltages high enough to kill through electrical shock.

- During installation, check the drawings and be sure to attach all hazard warning and caution labels.*
- Always break the primary circuit of the power supply when direct access to the heater or wiring is required.*

Read the safety section in the front of this manual.

The diffusion pump has been designed to operate at a specific voltage. The voltage is specified on the label that is mounted on the side of the pump.

1. Verify the heater rating by measuring the resistance of the heater circuit and comparing it to the values in Table 1-1 on page 1-1.
2. Make the electrical connections in the junction box located near the foreline. The electrical supply should not be more than $\pm 5\%$ of the rated voltage.

CAUTION



All electrical connections should be made in accordance with all applicable state, local, and/or industrial codes.

1.2.7 Thermal Switch

The pump has been fitted with a manually-resettable thermal switch that is preset at the factory. This switch is located in a box near the bottom of the pump and provides protection to the pump in the event of excessive fluid loss, the loss of cooling water, or high inlet pressure.

WARNING



Failure to properly connect the thermal switch circuit can result in catastrophic injury to personnel and major damage to the pump or vacuum system.

- ❑ Connect the thermal switch in series with the heater.

In the event of overtemperature, the thermal switch opens and shut off the power to the pump.

Reset the thermal switch by pressing the button located at the center of the thermal switch. Do this only after the root cause of a problem has been determined and the appropriate corrective action taken.

This page intentionally left blank.

Section 2. Operation

CAUTION



- ❑ *Before turning on the heater, ensure there is fluid in the pump. Running the heater without fluid can ruin the heater and damage the pump.*
- ❑ *Do not air-release the pump while the boiler is hot. Most diffusion pump fluids are heat sensitive and breaks down under these conditions.*
- ❑ *Do not operate the pump without the internal splash baffle or foreline baffle in place. If the splash baffle is omitted, the pump may be unstable and operate at a low speed. If the foreline baffle is omitted, there may be excessive fluid loss.*
- ❑ *Do not operate the pump for extended periods at inlet pressures above 1 mTorr (1.3×10^{-3} mbars). High-pressure operation can cause excessive backstreaming.*
- ❑ *Do not operate the pump heater unless cooling water is circulating. It causes the pump fluid to overheat.*

2.1 Startup

During initial operation of the diffusion pump, a fresh charge of diffusion pump oil may go through a degassing process. This can result in inlet and foreline pressure fluctuations. These pressure fluctuations are normal.

1. Visually inspect the sight glass assembly to ensure that the diffusion pump has been charged with the proper amount of diffusion pump fluid.

When properly filled, the oil level (when the pump is cold) is even with the FULL/COLD mark on the oil level indicator.

2. Evacuate the diffusion pump (rough pump) with a mechanical backing pump (customer supplied).

The pressure must be reduced to less than 0.5 Torr (.66 mbars). The backing pump should remain connected to the foreline of the diffusion pump.

3. Turn on the cooling water supply to the pump body and verify that the cooling water is not being supplied to the Quick Cool Coil at this time.
4. Turn on the power to the diffusion pump heater.

VHS-4, VHS-6 and VHS-250 Diffusion Pumps

5. Monitor inlet and foreline pressures.

During operation of the diffusion pump:

- The gas load at the inlet should not exceed the maximum throughput capability of the pump.
- The forepressure should not exceed the specified tolerable forepressure.

2.2 Shutdown

1. Turn off the power to the diffusion pump and continue to back the diffusion pump with the appropriate mechanical pump.
2. Allow cooling water to flow through the diffusion pump until the pump body temperature, located just above the boiler plate, has cooled to a temperature of approximately 130 °F.

After isolating the backing pump, the diffusion pump can be vented to atmosphere.

If faster cooling is desired, the pump can be cooled using the Quick Cool Coil at the bottom of the diffusion pump.

Section 3. Maintenance and Service

3.1 General Maintenance

Diffusion pumps generally require little attention when operated correctly. It is advisable to perform some periodic inspections to ensure trouble-free operation. By performing simple preventive maintenance, costly downtime can be avoided. A day-to-day log of pump and system performance helps indicate the condition of the pump and the need for corrective action.

3.2 Inspection Requirements

The frequency of inspections depends on the type of system, its operation, and its use. The maximum interval between inspections is established on the basis of experience. Vacuum Technologies recommends that you examine the following items regularly:

- ✓ When the pump is cold, check the condition and level of the fluid.
 - ❑ Withdraw a fluid sample through the drain and visually check the level of the fluid through the sight glass. A slight discoloration of the fluid does not affect performance.



Always use new O-rings when replacing fill plugs or the sight glass.

Loss of fluid can be caused by any of the following conditions:

- ❑ Incorrect venting procedures and/or admittance of excessive air or other gas to a hot pump
 - ❑ Inadequate water cooling
 - ❑ Prolonged operation at inlet pressures above 10^{-3} Torr (1.33×10^{-3} mbar)
 - ❑ Failure to reinsert the foreline baffle in the pump assembly
- ✓ Check the total heater power input.
 - ❑ When the pump is cold and the power is off, ensure that the heater is bolted snugly to the boiler plate.
 - ❑ Verify that all heater terminal connections at the heater and inside the junction box are tight and in good condition.

- Ensure that the cooling water flow is adequate and unobstructed. In areas where the mineral content of the water is high or where there is considerable sediment, it may be advisable to install water filters.

3.3 Cleaning

Complete cleaning of the pump may be required due to the gradual deterioration of pump fluids. Removal of the pump from the system is necessary.

To clean the pump:

1. Turn off the power and disconnect the power supply plug.
2. Allow the pump to cool, then turn off the cooling water and disconnect the cooling lines.
3. Unbolt the inlet flange and foreline connections.
4. Remove the pump from the system.
5. Drain the diffusion pump of all fluid.
6. Remove all O-rings, then remove the cold cap assembly, the jet assembly, and the foreline baffle from the pump.
7. Thoroughly clean the diffusion pump body interior and the jet assembly using acetone followed by an isopropyl alcohol rinse.
8. Dry the pump and the jet assembly with clean, dry, oil-free compressed air.
9. Install the foreline baffle, the jet assembly, and the cold cap assembly in the pump body.
 - Verify that the ejector nozzle is properly aligned with the foreline.
 - Verify that the cold cap is properly installed on the jet assembly. The space between the underside of the cold cap and the outside of the jet cap should be uniform.
10. Reinstall the diffusion pump in the system using all new O-rings.
11. Charge the pump with the proper amount of fluid.
12. Reconnect the water cooling lines and the power supply.
13. Evacuate the diffusion pump with the appropriate mechanical pump and turn on the cooling water.
14. After the pump has been evacuated to a pressure below 0.5 Torr (.66 mbars), turn on the power to the diffusion pump.

3.4 VHS-4 and VHS-6 Cold Cap Removal/Installation

To remove the cold cap:

1. Remove the spring (1) (Figure 3-1) attached by round head screw (2), a flat washer (3) and a lock washer (4). The screw types are:
 - ❑ VHS-4: no. 8-32x3/16
 - ❑ VHS-6: no. 6-32x3/16
2. Loosen the nut (5) holding the cold cap bracket (6) to the copper bar (A) and remove the cold cap (7) from the top of the jet cap (8).
3. Unscrew the no. 8-32x1/4 socket head cap screw (9) from the top of the ceramic standoff (10).
4. Remove the ceramic standoff (10) and the no. 8-32x1/2 stud (11).

To install the cold cap:

1. Thread the 8-32 stud (11) into the ceramic bushing (10) until it bottoms (finger tight).
2. Thread the 8-32 hex socket head screw (9) into top of ceramic bushing (10) until it bottoms.
3. Install the ceramic bushing assembly onto the top of the jet cap (8) by threading stud (11) into the tapped hole in the top jet cap. Install finger tight.
4. Attach spring clip (1) to cold cap (7) with 6-32 screw (2) and washers (3 and 4) so that the clip rests on top of sleeve (12).
5. Lower the cold cap assembly carefully onto the top of the jet cap assembly (8). The ceramic bushing fits in sleeve (12) and the clamp bar (6) straddles the body bar (A).
6. Lower the cold cap until the horizontal portion of the spring clip (1) touches the head of screw (9). Ensure that the clearance between the cold cap and the top jet cap is even around the periphery and that the cold cap assembly is level with the pump inlet flange.
7. Carefully tighten the captive bolt (5) ensuring that there is no strain on the ceramic bushing and no shift in the position of the cold cap.

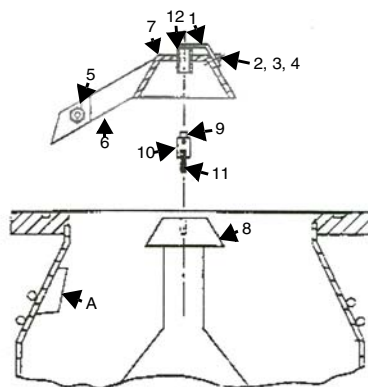

Figure 3-1 VHS4 and VHS-6 Cold Cap Removal/Installation

3.5 VHS-250 Cold Cap Removal/Installation

To remove the cold cap:

1. Remove the spring (J) attached by the 6-32x3/16 round head screw (H), a flat washer and a lock washer (Figure 3-2).
2. Loosen the nuts (L) holding the cold cap bracket (E) to the copper bar (C) and remove the cold cap (B) from the top of the jet cap (A).
3. Unscrew the no. 8-32x1/4 socket head cap screw (G) from the top of the ceramic standoff (D).
4. Remove the ceramic standoff (D) and the no. 8-32x1/2 stud (F).

To install the cold cap:

1. Thread the 8-32 stud (F) into the ceramic bushing (O) until it bottoms (finger tight).
2. Thread the 8-32 hex socket head screw (G) into top of ceramic bushing (O) until it bottoms.
3. Install the ceramic bushing assembly onto the top of the jet cap (A) by threading stud (F) into the tapped hole in the top jet cap. Install finger tight.
4. Attach spring clip (J) to cold cap (8) with 6-32 screw (H) so that the clip rests on top of sleeve (K).
5. Lower the cold cap assembly carefully onto the top of the jet cap assembly (A). The ceramic bushing fits in sleeve (K) and the clamp bars (E) straddle the body bar (C).
6. Lower the cold cap until the horizontal portion of the spring clip (J) touches the head of screw (G). Ensure that the clearance between the cold cap and the top jet cap is even around the periphery and that the cold cap assembly is level with the pump inlet flange.
7. Carefully tighten the captive bolts (L) ensuring that there is no strain on the ceramic bushing and no shift in the position of the cold cap.

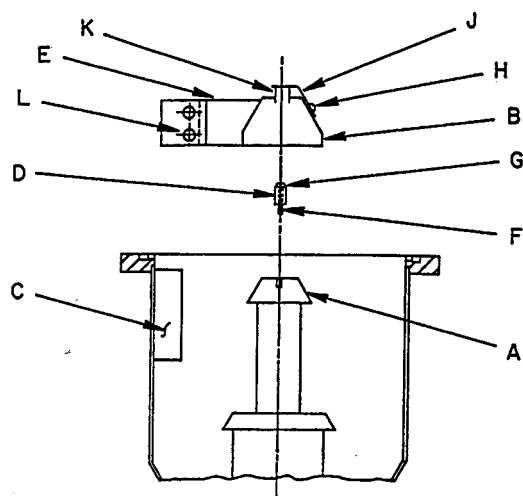

Figure 3-2 VHS-250 Cold Cap Removal/Installation

3.6 Jet Assembly Removal/Installation

To remove the jet assembly:

1. Remove the cold cap from the pump (Figure 3-3).
2. Unscrew the top cap from the jet assembly.
3. Lift out each section of the jet assembly, being careful not to dent or otherwise damage the jet assembly during disassembly or cleaning.
4. Remove the splash baffle from the pump.

To install the jet assembly:

1. Place the splash baffle in the bottom of the pump and verify that it is located in the outer boiler groove.
2. Insert the jet base, making sure the ejector is aligned with the foreline and that the slot in the jet base locks onto the alignment pin.
3. Assemble the remaining stages of the jet.
 - Verify that all the stages are firmly seated.
 - Verify that all the drip shields are in place.
4. Install the cold cap assembly.

VHS-4, VHS-6 and VHS-250 Diffusion Pumps

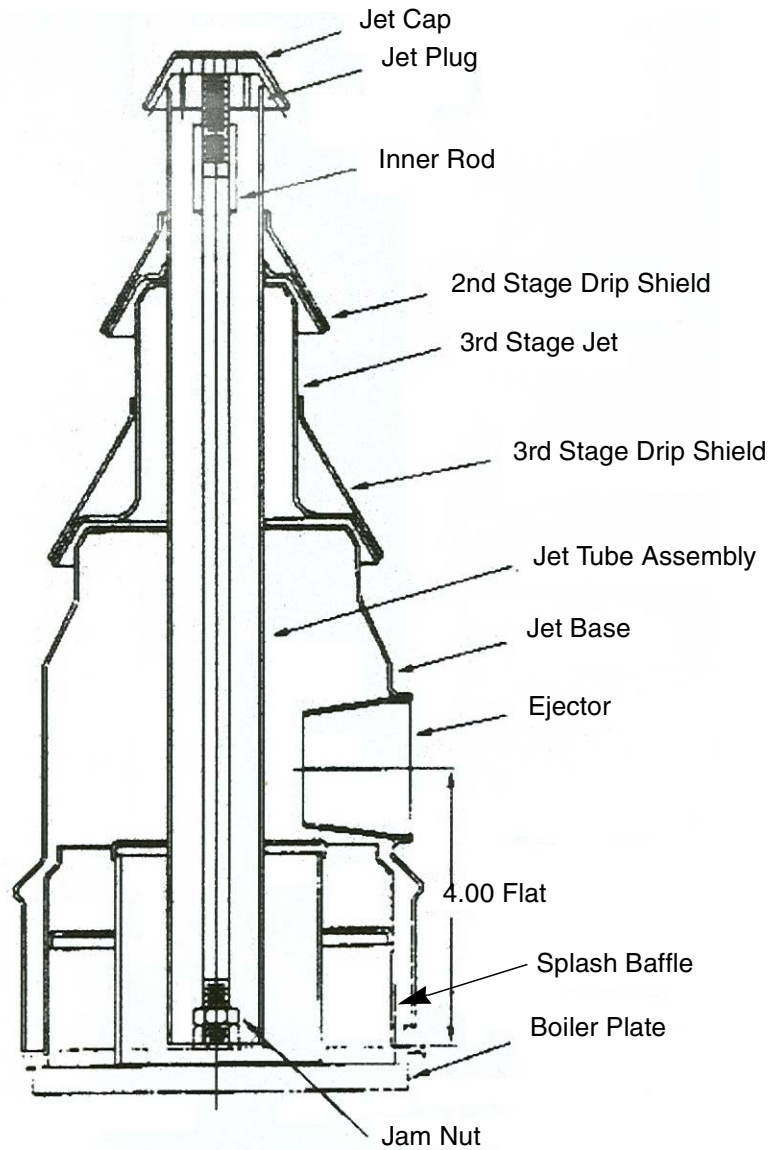

Figure 3-3 VHS-4 Diffusion Pump Jet Assembly

VHS-4, VHS-6 and VHS-250 Diffusion Pumps

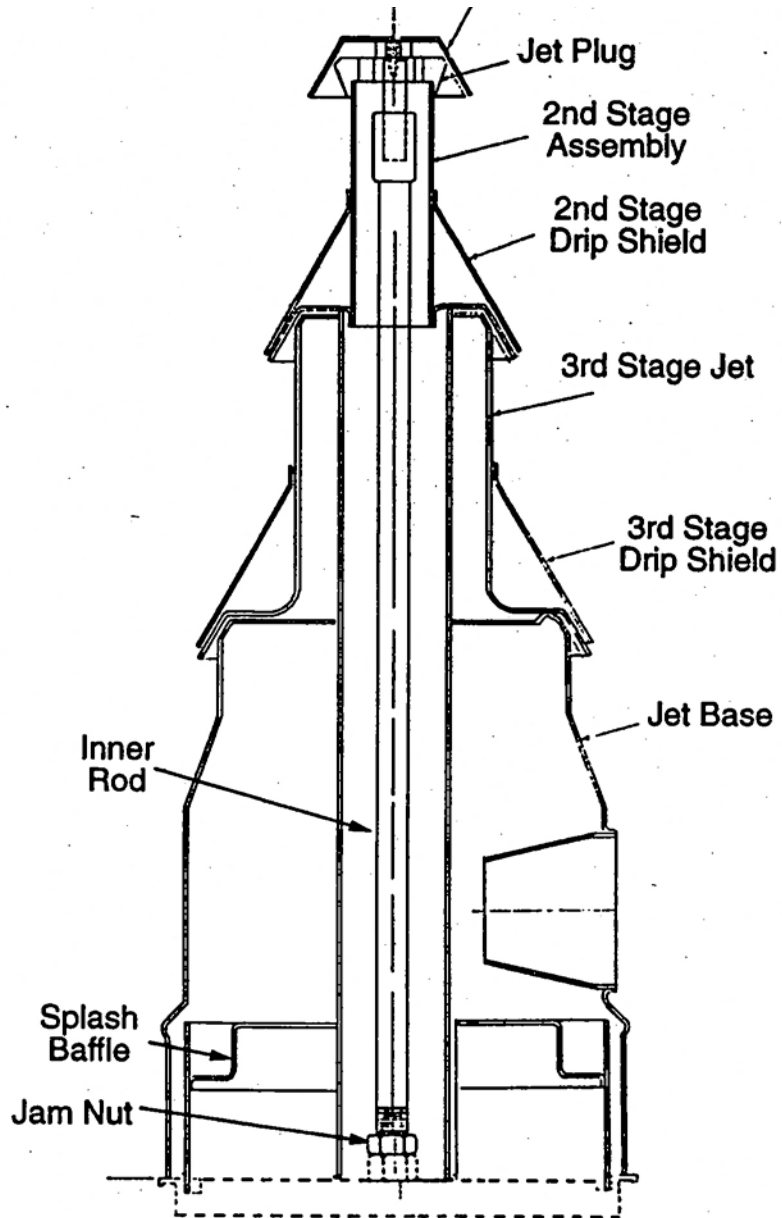

Figure 3-4 VHS-6 and 250 Diffusion Pump Jet Assembly

3.7 Heater Replacement

Refer to Figure 3-5 (VHS-6 and VHS-250) and Figure 3-6 (VHS-4) for this procedure:

1. Turn off the power to the diffusion pump and disconnect the power supply.
2. Remove the heater cover and the insulation from the bottom of the diffusion pump.
3. Label the heater wires for proper location during installation.
4. Disconnect the terminal leads.

Use two wrenches when loosening (one on each nut) to prevent excessively torquing and possibly breaking the heater terminals.

5. Remove the nut holding the heater clamp.
6. Lower the entire heater unit from the pump and replace the defective heater.
7. Coat the boiler stud with an anti-seize compound such as FEL-PRO C5A or common milk of magnesia.
8. Support the heater unit by the heater clamp, line up the hole with the boiler stud, and push the unit up against the boiler plate.
9. Finger-tighten the nut to hold it in place.
10. Tighten the heater clamp bolt to a torque of 250 inch-pounds.
11. Replace the heater insulation and cover.

Heater Element

647306125 2200 W, 120 V
647306175 2200 W, 208 V
647306225 2200 W, 240 V

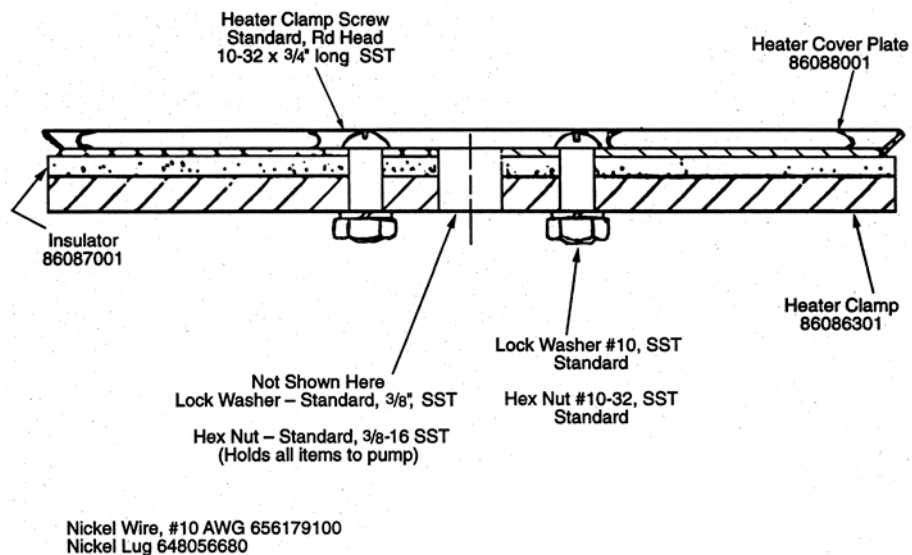

Figure 3-5 VHS-6 and VHS-250 Heater Mounting

VHS-4, VHS-6 and VHS-250 Diffusion Pumps

Heater Element

647304205 1450 W, 120 V

647304210 1450 W, 208 V

647304250 1450 W, 240 V

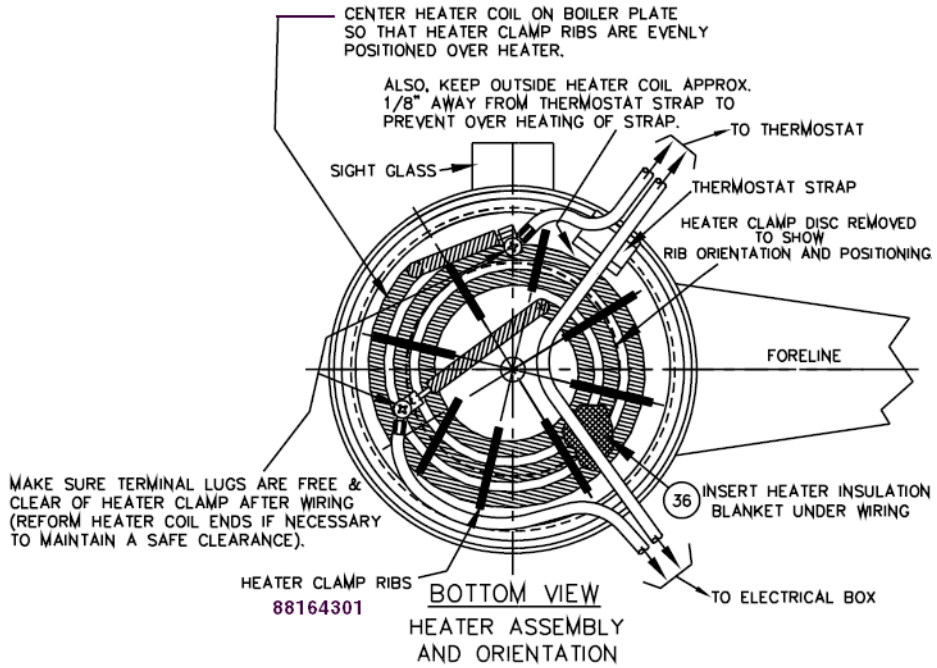

Figure 3-6 VHS-4 Heater Mounting

3.8 Pump Fluid Charge

The recommended fluid charge is:

- ❑ 300 cc for the VHS-4
- ❑ 500 cc for VHS-6 and VHS-240

The fluid charge will gradually be depleted through use, but the pump will continue to operate normally.

When the charge is reduced to approximately 60% of the initial fill amount, the boiler plate temperature may begin to rise. Under this condition, the thermal switch, when properly connected, is designed to open the heater circuit.

To add pump fluid:

1. Turn off power to the pump and allow the pump to cool until the temperature of the pump body (measured 1" above the heater skirt) has cooled to 130 °F.
2. Turn off the backing pump.
3. Vent the pump to atmosphere.
4. Loosen and remove the fill plug located at the top of the sight glass assembly.
5. Add pump fluid until the fluid level is even with the FULL/COLD mark on the sight glass.
6. Replace the O-ring in the fill plug and lubricate it with pump fluid.
7. Install the fill plug and tighten it moderately.
8. Evacuate the diffusion pump and start the pump as according to Section 2.1 "Startup" on page 2-1.

Section 4. Troubleshooting

4.1 Leakage

Analysis of general operational experience with diffusion pumps indicates that certain locations are more prone to vacuum leaks. The following locations should be checked first if leakage is the suspected cause of poor system performance:

- Inlet and foreline connections
- Drain and fill plugs
- Other compression fittings, such as high vacuum gauges in the system
- Threaded connections, such as foreline gauge

4.2 Outgassing

High vacuum systems, even without external leakage, can also exhibit high gas loads due to outgassing from internal surfaces or processes. The pressure in the system is a result of gas load divided by pumping speed ($P = Q/S$). If the gas load (Q) exceeds the maximum throughput capability of the diffusion pump, the diffusion pump will not function and the pumping action will essentially be performed by the mechanical backing pump.

To estimate gas load:

After evacuation, isolate the system from all pumps and measure the rate of pressure rise. The gas load created by the system can be estimated as:

$$Q = \frac{V \times \Delta P}{\Delta t}$$

Where:

V is the isolated volume

ΔP is the pressure rise, and

Δt is the time period of measurement

4.3 Poor Pump or System Performance

Before proceeding with a step-by-step troubleshooting program, check the performance and accuracy of the vacuum gauges used on the system. Table 4-1 shows the most frequent faults, their probable causes, and specific repair actions required for each.

Table 4-1 Troubleshooting

Symptom	Probable Cause	Repair Action
Poor system pressure	Leak in system — virtual or real.	Locate and repair.
	High process gas load.	Measure gas load, and eliminate the cause.
	System dirty.	Clean system to reduce outgassing.
Poor ultimate pressure	Contaminated pump fluid.	Examine, clean pump, and replace fluid.
	Low heat input.	Check voltage. Check for continuity, burned out element, poor thermal contact.
	Inadequate cooling water flow.	Check water pressure. Check tubing for obstructions or backpressure.
	Excessive or too cold cooling water.	Check temperature, adjust flow.
	High forepressure.	Check for leak in foreline, poor mechanical pump performance, breakdown of mechanical pump fluid.
	Water in Quick Cool Coil.	Check and remove water.
Slow pumpdown (prolonged cycle after checking gas load conditions)	Low heat input.	Check heaters.
	Low oil level.	Add oil.
	Malfunctioning pump assembly Improperly located jets. Damaged jet system.	Check and repair or replace.

VHS-4, VHS-6 and VHS-250 Diffusion Pumps

Table 4-1 Troubleshooting (Continued)

Symptom	Probable Cause	Repair Action
Inlet pressure surges	Incorrect heater voltage.	Check and correct voltage.
	Fluid outgassing.	Condition pump fluid by operating pump for a few hours.
	Leak in system ahead of pump inlet.	Check and correct.
High chamber contamination	Forepressure too high.	Check for leak in foreline, poor mechanical pump performance, breakdown of pump fluid, and incorrect valve operation.
	Prolonged operation at high throughput at pressure above 10^{-3} Torr (1.33×10^{-3} mbar).	Review operating procedures.
	Improper system operation air-release procedures.	Review operating procedures
Pump will not start	Safety circuits and/or protective devices prevent contactor from staying closed.	Check utilities, flow switches, interlocks, and thermostat operation.

This page intentionally left blank.

Section 5. Replacement Parts

Table 5-1 lists the VHS-4 models.

Table 5-2 lists the VHS-4 replacement parts available from Vacuum Technologies.

Table 5-1 VHS-4 Models

Pump	Voltage	Part Number		
		Flange Type		
		ASA	ISO	Conflat
Standard cold cap	120 V	86460301	L6256301	L6188301
Extended cold cap	120 V	86460311	L6256311	L6188311
Standard cold cap	208 V	86460306	L6256306	L6188306
Extended cold cap	208 V	86460316	L6256316	L6188316
Standard cold cap	240 V	86460302	L6256302	L6188302
Extended cold cap	240 V	86460312	L6256312	L6188312

Table 5-2 VHS-4 Replacement Parts

Part Number	Description
86488301	Standard Cold Cap Assembly
F6898301	Extended Cold Cap Assembly
L8908301	Sight Glass Repair Kit
F4785301	Jet Assembly
F4780 301	Splash Baffle
86754 301	Foreline Baffle Assembly
642906025	Switch
699006025	Standoff, ceramic insulating, Cold Cap
647304205	120 V / 1450 watt Heater Element
647304210	208 V / 1450 watt Heater Element
647306250	240 V / 1450 watt Heater Element
656179100	Wire, No. 10 stranded, nickel
648056680	Lugs, Replacement, nickel

VHS-4, VHS-6 and VHS-250 Diffusion Pumps

Table 5-2 VHS-4 Replacement Parts (Continued)

88164301	Heater Clamp
Commercial	Heater Clamp Nut, 3/16-16, Hex, stainless steel
694492156	Baffle Retaining Ring
K0377183	O-Ring Kit includes: <input type="checkbox"/> 3 Butyl inlet flange O-ring, Parker No. 2-258 <input type="checkbox"/> 10 Viton fill and drain O-rings (old style), Parker No. 2-112 <input type="checkbox"/> 10 Viton fill and drain O-rings (new style, Parker No. 2-113 <input type="checkbox"/> 1 Sight glass O-ring, Parker No. 2-226 <input type="checkbox"/> 1 Teflon gasket
K6948301	NEOVAC SY Diffusion Pump Fluid (1000 cc)
695474005	DC-704 Diffusion pump Fluid (500 cc)
695475005	DC-70S Diffusion Pump Fluid (500 cc)
695405005	Santovac 5 Diffusion Pump Fluid (500 cc)
86715001	Spring, Cold Cap
Commercial	Screw, Rd hd machine, no. 8-32x3/16, stainless steel
Commercial	Stud, no. 8-32 x 1/2, stainless steel
Commercial	Screw, Socket hd cap, no. 8-32x1/4, stainless steel

Table 5-3 lists the VHS-6 models.

Table 5-4 lists the VHS-6 replacement parts available from Vacuum Technologies.

Table 5-3 VHS-6 Models

Pump	Voltage	Part Number		
		Flange Type		
		ASA	ISO	Conflat
Standard cold cap	120 V	85826301	L6193301	L6200301
Extended cold cap	120 V	85826311	L6193311	L6200311
Standard cold cap	208 V	85826306	L6193306	L6200306
Extended cold cap	208 V	85826316	L6193316	L6200316
Standard cold cap	240 V	85826302	L6193302	L6200302
Extended cold cap	240 V	85826312	L6193312	L6200312

VHS-4, VHS-6 and VHS-250 Diffusion Pumps

Table 5-4 VHS-6 Replacement Parts

Part Number	Description
86488301	Standard Cold Cap Assembly
F6455301	Extended Cold Cap Assembly
F3365301	Jet Assembly
F3373301	Splash Baffle
L9172301	Foreline Baffle Assembly
642906025	Thermoswitch Kit
699006025	Standoff, ceramic insulating, Cold Cap
647306125	120 V / 2200 watt Heater Element
647306225	208 V / 2200 watt Heater Element
647306175	240 V / 2200 watt Heater Element
656179100	Wire, No. 10 stranded, nickel
648056680	Lugs, Replacement, nickel
86087001	Heater Insulator
86086301	Heater Clamping Plate
86088301	Heater Cover Plate
L8998001	Heater Insulating Blanket
L8997001	Heater Cover
K0377184	O-Ring Kit includes: <input type="checkbox"/> 3 Butyl inlet flange O-ring, Parker No. 2-267 <input type="checkbox"/> 3-Butyl-N foreline flange O-ring, Parker No. 2-332 <input type="checkbox"/> 10 Viton fill and drain O-rings (old style), Parker No. 2-112 <input type="checkbox"/> 10 Viton fill and drain O-rings (new style, Parker No. 2-113 <input type="checkbox"/> 1 Teflon gasket <input type="checkbox"/> 1 Sight glass O-ring, Parker No. 2-226
K6948301	NEOVAC SY Diffusion Pump Fluid (1000 cc)
695474005	DC-704 Diffusion pump Fluid (500 cc)
695475005	DC-70S Diffusion Pump Fluid (500 cc)
695405005	Santovac 5 Diffusion Pump Fluid (500 cc)
86715001	Spring, Cold Cap
Commercial	Screw, Rd hd machine, no. 6-32x3/16, stainless steel

VHS-4, VHS-6 and VHS-250 Diffusion Pumps

Table 5-4 VHS-6 Replacement Parts (Continued)

Commercial	Washer, flat, no. 6, stainless steel
Commercial	Washer, lock, no. 6, stainless steel
Commercial	Stud, no. 8-32 x 1/2, stainless steel
Commercial	Screw, Socket hd cap, no. 8-32x1/4, stainless steel

Table 5-5 lists the VHS-250 models.

Table 5-6 lists the VHS-250 replacement parts available from Vacuum Technologies.

Table 5-5 VHS-250 Models

Pump	Voltage	Part Number
		Flange Type
		ISO
Standard cold cap	120 V	K0543301
Standard cold cap	208 V	K0543306
Standard cold cap	240 V	K0543302

Table 5-6 VHS-250 Replacement Parts

Part Number	Description
F9584301	Standard Cold Cap Assembly
F9548301	Jet Assembly
F3373301	Splash Baffle
L9172301	Foreline Baffle Assembly
642906025	Thermoswitch Kit
699006025	Standoff, ceramic insulating, Cold Cap
647306125	120 V / 2200 watt Heater Element
647306225	208 V / 2200 watt Heater Element
647306175	240 V / 2200 watt Heater Element
656179100	Wire, No. 10 stranded, nickel
648056680	Lugs, Replacement, nickel
86087001	Heater Insulator
86086301	Heater Clamping Plate

VHS-4, VHS-6 and VHS-250 Diffusion Pumps

Table 5-6 VHS-250 Replacement Parts (Continued)

86088301	Heater Cover Plate
L8998001	Heater Insulating Blanket
L8997001	Heater Cover
K0377178	O-Ring Kit includes: <input type="checkbox"/> 3 Butyl inlet flange O-ring, Parker No. 2-332 <input type="checkbox"/> 3-Butyl-N foreline flange O-ring, Parker No. 2-379 <input type="checkbox"/> 10 Viton fill and drain O-rings (old style), Parker No. 2-112 <input type="checkbox"/> 10 Viton fill and drain O-rings (new style, Parker No. 2-113 <input type="checkbox"/> 1 Teflon gasket <input type="checkbox"/> 1 Sight glass O-ring, Parker No. 2-226
K6948301	NEOVAC SY Diffusion Pump Fluid (1000 cc)
695474005	DC-704 Diffusion pump Fluid (500 cc)
695475005	DC-70S Diffusion Pump Fluid (500 cc)
695405005	Santovac 5 Diffusion Pump Fluid (500 cc)
86715001	Spring, Cold Cap
Commercial	Screw, Rd hd machine, no. 6-32x3/16, stainless steel
Commercial	Washer, flat, no. 6, stainless steel
Commercial	Washer, lock, no. 6, stainless steel
Commercial	Stud, no. 8-32 x 1/2, stainless steel
Commercial	Screw, Socket hd cap, no. 8-32x1/4, stainless steel

This page intentionally left blank.



*Request for Return
Health and Safety Certification*



- Return authorization numbers (RA#) **will not** be issued for any product until this Certificate is completed and returned to a Varian, Inc. Customer Service Representative.
- Pack goods appropriately and drain all oil from rotary vane and diffusion pumps (for exchanges please use the packing material from the replacement unit), making sure shipment documentation and package label clearly shows assigned Return Authorization Number (RA#) VVT cannot accept any return without such reference.
- Return product(s) to the nearest location:

North and South America
 Varian, Inc.
 Vacuum Technologies
 121 Hartwell Ave.
 Lexington, MA 02421
 Fax: (781) 860-9252

Europe and Middle East
 Varian S.p.A.
 Via F.lli Varian, 54
 10040 Leini (TO) – ITALY
 Fax: (39) 011 997 9350

Asia and ROW
 Varian Vacuum Technologies
 Local Office

For a complete list of phone/fax numbers see www.varianinc.com/vacuum

- If a product is received at Varian, Inc. in a contaminated condition, **the customer is held responsible** for all costs incurred to ensure the safe handling of the product, and **is liable** for any harm or injury to Varian, Inc. employees occurring as a result of exposure to toxic or hazardous materials present in the product.

CUSTOMER INFORMATION			
Company name:			
Contact person:	Name:	Tel:.....
	Fax:	E-mail:
Ship method:	Shipping Collect #:	P.O.#:
Europe only:	VAT Reg Number:	USA only:	<input type="checkbox"/> Taxable <input type="checkbox"/> Non-taxable
Customer ship to:	Customer bill to:

PRODUCT IDENTIFICATION

Product Description	Varian, Inc. Part Number	Varian, Inc. Serial Number

TYPE OF RETURN (check appropriate box)

<input type="checkbox"/> Paid Exchange	<input type="checkbox"/> Paid Repair	<input type="checkbox"/> Warranty Exchange	<input type="checkbox"/> Warranty Repair	<input type="checkbox"/> Loaner Return
<input type="checkbox"/> Credit	<input type="checkbox"/> Shipping Error	<input type="checkbox"/> Evaluation Return	<input type="checkbox"/> Calibration	<input type="checkbox"/> Other

HEALTH and SAFETY CERTIFICATION

VACUUM TECHNOLOGIES CANNOT ACCEPT ANY BIOLOGICAL HAZARDS, RADIOACTIVE MATERIAL, ORGANIC METALS, OR MERCURY AT ITS FACILITY. CHECK ONE OF THE FOLLOWING:		
<input type="checkbox"/> I confirm that the above product(s) has (have) NOT pumped or been exposed to any toxic or dangerous materials in a quantity harmful for human contact.		
<input type="checkbox"/> I declare that the above product(s) has (have) pumped or been exposed to the following toxic or dangerous materials in a quantity harmful for human contact (<u>Must be filled in</u>):		
Print Name	Signature	Date

PLEASE FILL IN THE FAILURE REPORT SECTION ON THE NEXT PAGE

Do not write below this line

Notification (RA) #: Customer ID #: Equipment #:



FAILURE REPORT

(Please describe in detail the nature of the malfunction to assist us in performing failure analysis):

TURBO PUMPS AND TURBOCONTROLLERS

Claimed Defect	Position	Parameters
<input type="checkbox"/> Does not start <input type="checkbox"/> Does not spin freely <input type="checkbox"/> Does not reach full speed <input type="checkbox"/> Mechanical Contact <input type="checkbox"/> Cooling defective <input type="checkbox"/> Noise <input type="checkbox"/> Vibrations <input type="checkbox"/> Leak <input type="checkbox"/> Overtemperature <input type="checkbox"/> Clogging	<input type="checkbox"/> Vertical <input type="checkbox"/> Horizontal <input type="checkbox"/> Upside-down <input type="checkbox"/> Other	Power: Rotational Speed: Current: Inlet Pressure: Temp 1: Foreline Pressure: Temp 2: Purge flow: Operation Time:
Describe Failure:		
Turbocontroller Error Message:		

ION PUMPS/CONTROLLERS

<input type="checkbox"/> Bad feedthrough <input type="checkbox"/> Vacuum leak <input type="checkbox"/> Error code on display <input type="checkbox"/> Poor vacuum <input type="checkbox"/> High voltage problem <input type="checkbox"/> Other
Describe failure:
Customer application:

VALVES/COMPONENTS

<input type="checkbox"/> Main seal leak <input type="checkbox"/> Solenoid failure <input type="checkbox"/> Damaged sealing area <input type="checkbox"/> Bellows leak <input type="checkbox"/> Damaged flange <input type="checkbox"/> Other
Describe failure:
Customer application:

LEAK DETECTORS

<input type="checkbox"/> Cannot calibrate <input type="checkbox"/> Vacuum system unstable <input type="checkbox"/> Failed to start <input type="checkbox"/> No zero/high background <input type="checkbox"/> Cannot reach test mode <input type="checkbox"/> Other
Describe failure:
Customer application:

INSTRUMENTS

<input type="checkbox"/> Gauge tube not working <input type="checkbox"/> Communication failure <input type="checkbox"/> Error code on display <input type="checkbox"/> Display problem <input type="checkbox"/> Degas not working <input type="checkbox"/> Other
Describe failure:
Customer application:

ALL OTHER VARIAN, INC.

<input type="checkbox"/> Pump doesn't start <input type="checkbox"/> Doesn't reach vacuum <input type="checkbox"/> Pump seized <input type="checkbox"/> Noisy pump (describe) <input type="checkbox"/> Overtemperature <input type="checkbox"/> Other
Describe failure:
Customer application:

DIFFUSION PUMPS

<input type="checkbox"/> Heater failure <input type="checkbox"/> Doesn't reach vacuum <input type="checkbox"/> Vacuum leak <input type="checkbox"/> Electrical problem <input type="checkbox"/> Cooling coil damage <input type="checkbox"/> Other
Describe failure:
Customer application:

Sales and Service Offices

Canada

Central coordination through:

Varian, Inc.
121 Hartwell Avenue
Lexington, MA 02421
USA
Tel: (781) 861 7200
Fax: (781) 860 5437
Toll Free: (800) 882 7426

China

Varian Technologies - Beijing

Room 1201, Jinyu Mansion
No. 129A, Xuanwumen Xidajie
Xicheng District
Beijing 1000031
P.R. China
Tel: (86) 10 6608 1031
Fax: (86) 10 6608 1541

France and Benelux

Varian s.a.

7 avenue des Tropiques
Z.A. de Courtaboeuf – B.P. 12
Les Ulis cedex (Orsay) 91941
France
Tel: (33) 1 69 86 38 13
Fax: (33) 1 69 28 23 08

Germany and Austria

Varian Deutschland GmbH

Alsfelder Strasse 6
Postfach 11 14 35
64289 Darmstadt
Germany
Tel: (49) 6151 703 353
Fax: (49) 6151 703 302

India

Varian India PVT LTD

101-108, 1st Floor
1010 Competent House
7, Nangal Raya Business Centre
New Delhi 110 046
India
Tel: (91) 11 5548444
Fax: (91) 11 5548445

Italy

Varian, Inc.

Via F.lli Varian, 54
10040 Leini, (Torino)
Italy
Tel (39) 011 997 9 111
Fax (39) 011 997 9 350

Japan

Varian, Inc.

Sumitomo Shibaura Building, 8th Floor
4-16-36 Shibaura
Minato-ku, Tokyo 108
Japan
Tel: (81) 3 5232 1253
Fax: (81) 3 5232 1263

Korea

Varian Technologies Korea, Ltd.

Shinsa 2nd Building 2F
966-5 Daechi-dong
Kangnam-gu, Seoul
Korea 135-280
Tel: (82) 2 3452 2452
Fax: (82) 2 3452 2451

Mexico

Varian S.A.

Concepcion Beistegui No 109
Col Del Valle
C.P. 03100
Mexico, D.F.
Tel: (52) 5 523 9465
Fax: (52) 5 523 9472

Russia

Central coordination through:

Varian, Inc.
via F.lli Varian 54
10040 Leini, (Torino)
Italy
Tel: (39) 011 997 9 252
Fax: (39) 011 997 9 316

Taiwan

Varian Technologies Asia Ltd.

18F-13 No.79, Hsin Tai Wu Road
Sec. 1, Hsi Chih, Taipei Hsien
Taiwan, R.O.C.
Tel: (886) 2 2698 9555
Fax: (886) 2 2698 9678

UK and Ireland

Varian Ltd.

28 Manor Road
Walton-On-Thames
Surrey KT 12 2QF
England
Tel: (44) 1932 89 8000
Fax: (44) 1932 22 8769

United States

Varian, Inc.

121 Hartwell Avenue
Lexington, MA 02421
USA
Tel: (781) 861 7200
Fax: (781) 860 5437

Other Countries

Varian, Inc.

Via F.lli Varian 54
10040 Leini, (Torino)
Italy
Tel: (39) 011 997 9 111
Fax: (39) 011 997 9 350

Customer Support and Service:

North America

Tel: 1 (800) 882-7426 (toll-free)
vtl.technical.support@varianinc.com

Europe

Tel: 00 (800) 234 234 00 (toll-free)
vtl.technical.support@varianinc.com

Japan

Tel: (81) 3 5232 1253 (dedicated line)
vtj.technical.support@varianinc.com

Korea

Tel (82) 2 3452 2452 (dedicated line)
vtk.technical.support@varianinc.com

Taiwan

Tel: 0 (800) 051 342 (toll-free)
vtw.technical.support@varianinc.com

Worldwide Web Site, Catalog and On-line Orders:

www.varianinc.com

Representatives in most countries



VARIAN

