

**ENGLISH VERSION SYNTHESIS OF JUAN.L.CALVO'S BOOK
 "PISTOLAS Y REVÓLVERES EN LAS FUERZAS ARMADAS ESPAÑOLAS, 1855-1955"
 (PISTOLS AND REVOLVERS IN THE SPANISH ARMED FORCES, 1855-1955)
 TRANSLATION BY HECTOR.J.MERUELO**

Originally Published in Barcelona in 2003

All rights reserved and copyrighted

Legal Deposit B.40.411-2003

Reproduction of this work, totally or partially, by any means or method,
 without the author's previous authorization, is forbidden by law;

However, it may be downloaded for personal use,
 as a service to the collecting community

PART TWO

AUTOMATIC AND SIGNALS PISTOLS, 1903-1945

THE FIRST AUTOMATIC PISTOLS

When the invention of smokeless powder made possible the design of reliable mechanisms and the so called "automatic pistols" first appeared in the market, in Spain the Oviedo Factory, overseen by the Artillery Corps, and some of the private factories in Eibar, were ready to produce them.

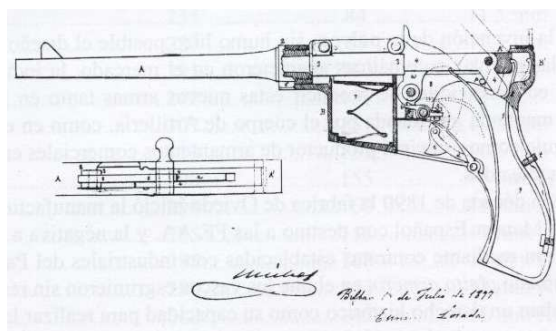

The Losada pistol as illustrated in its patent application of 1897.

In contrast to what happened with the revolvers, where (Spanish) production was based on English, French and North American models, in the conception of automatic pistols some Spanish designers did make original contributions from the very beginnings; The first one to apply for a patent for this type of weapon was the Artillery officer Don Enrique Losada y del Corral (1850-1916); One year later the Eibar firm of "Charola y Anitua" obtained a patent for his pistol; This firm was the successor of Anitua y Charola, makers of the Merwin revolvers from 1881-1897.

The Losada pistol was never marketed and in 1907 was still considered a "project"; The Charola y Anitua pistol, in 5 mm caliber, was commercialized by this firm which was partnered by Don Ignacio Charola and Don Miguel Anitua; It was dissolved in 1900 and

from that point on Don Ignacio Charola continued to manufacture the pistols, one model in 5 mm caliber and another one in 7mm.

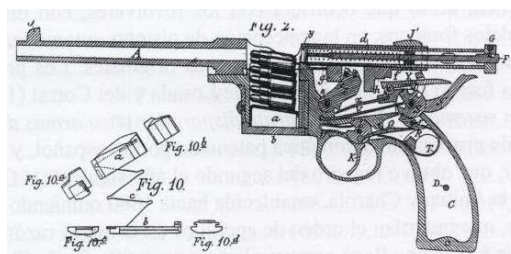

The "Charola y Anitua" pistol as illustrated in its patent application of 1898.

THE BERGMANN PISTOLS, MODELS OF 1903 AND 1908

In 1896 the Artillery Corps started to consider substituting the revolvers then being used by officers and troops, by an "automatic" pistol; In charge of this study was first a Mixed Handguns Commission, followed by the Technical Board, and then the Trials Commission; Almost ten years later comparative studies had been made of all models then available and the Commission decided in favor of the Model 1903 Bergmann 9mm, and "the short and long Mauser models" of the same year (probably referring to variations of the C96 broom handle pistol), although, "in consideration of ease of manufacture and price" preference was given to the Bergmann, which also had the additional advantage of two loading systems: by stripper clip and by magazine.

In accordance with the conclusions reached by the Trials Commission, on September, 5, 1905, the Bergmann pistol was declared a regulation sidearm with the official denomination of "Bergmann pistol of 9mm Model 1903" and the Artillery Section was directed to engage in negotiations to acquire the needed number of pistols, each one with two magazines; The Trials Commission was responsible for establishing the technical requirements to be demanded in the contract and the test trials to be made upon receiving them; In the Commission's opinion they should be submitted "all of them, one by one, to a firing trial, to be preceded and followed by a detailed examination, each one firing the twelve rounds in its two magazines and, of those approved, grouped in lots of 1,000, five would be selected at random from all lots, for endurance firing of 400 rounds in rapid fire, preceded and followed by 10 shots in slow fire for penetration and accuracy testing".

It was also stipulated that for General Officers, Chiefs and Officers, who would have to purchase their personal gear, the Bergmann pistol was not "obligatory"; In these cases, this model's adoption was only a "recommendation", which in the future could be amplified to include other models then under study, preferably those of "Spanish authors"; However, the necessary standardization of ammunition made it advisable that any pistol used by the Army be chambered for the 9 mm Bergmann round.

The Army put in an order for 3,000 pistols but Theodor Bergmann could not find a manufacturer willing to produce them so, in 1907 he sold the rights to his patent to the firm "Anciens Etablissements Pieper" of Herstal, Belgium, who then produced them in the variation denominated "Model of 1908"; Consequently the Spanish Government, on November, 16, 1909, annulled the previous disposition and adopted, in substitution of the Model 1903 pistol, the "Bergmann pistol of 9mm Model 1908"; With the unavoidable delay, Anciens Etablissements Pieper then started to deliver this model in several shipments, not completing the 3,000 unit contract until 1910.

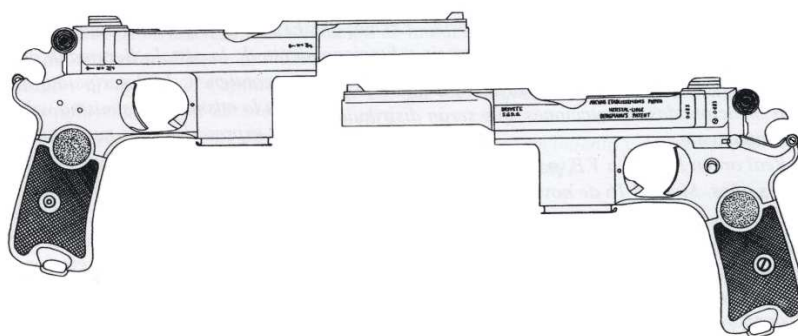

The Bergmann pistol of 9mm. Model 1908. Six shot magazine in 9mm Bergmann caliber.

These pistols were destined to equip Sergeants, other NCO's and the bicycle sections of Infantry regiments; Once their distribution got under way so did the complaints of those who used them; This is reflected in the book "Armas y Defensa" (Weapons and Defense) by Lieutenant-Colonel and shooting champion Don Antonio Vázquez de Aldana, who felt that, the six shots in their magazines were insufficient, that their safety was unreliable and "caused lamentable accidents", that their mechanism made them prone to jamming , etc, and concluded that the Bergmann was a "very well studied but poorly constructed" pistol and that in its manufacture the tendency was to "cheap but not quality, construction".

On October, 17, 1910, the yearly ammunition issue was to be 25 rounds per pistol, increased to 50 rounds on December, 26, 1911 which prompted Vázquez de Aldana to say that the Bergmann's defects were magnified by this meager allotment, which made it impossible for its users to get to know the pistol in the only way he knew how: "by burning a lot of powder"

Once the Bergmann pistol's deficiencies were recognized their purchase was limited to the original 3,000 but, upon adopting the Campo-Giro pistol it was proclaimed that its adoption "did not imply decommissioning the Bergmann pistols in use today and, consequently those who are using them may continue to do so".

THE CAMPO-GIRO PISTOLS, MODELS OF 1912, 1913 AND 1913-16.

The Campo-Giro pistol was the brainchild of Don Venancio López de Ceballos y Aguirre, Count of Campo-Giro (1856-1916), an officer of the Army General Staff, who, on October, 20, 1904, obtained an initial patent; One year later its study and experimentation at the Oviedo factory was authorized.

Four specimens were ordered made in Oviedo but not until 1908 were they ready to be tested due to the delay caused by the modifications made necessary by the adoption of the 9mm Bergmann round; Then the construction of another 25 units was authorized, also in Oviedo, which incorporated the improvements derived from the testing of the first four, and after testing these 25 the "Campo-Giro pistol of 9mm Model 1912" was adopted as regulation sidearm "for Chiefs, Officers and troops"; It was to use the same round as the Bergmann pistol, although a few weeks later the powder charge was reduced from 0.48 to 0.40 grams.

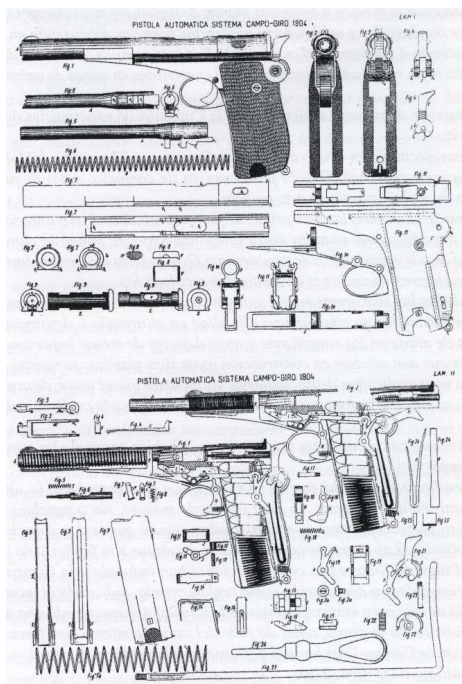

The "Campo-Giro" pistol as illustrated in its patent application of 1904.

In 1911 Don Venancio López de Ceballos registered the modifications that had been made to his patented 1904 pistol and, the following year, he registered, as an "industrial factory model", the property of the model that was about to enter mass production at the Oviedo factory.

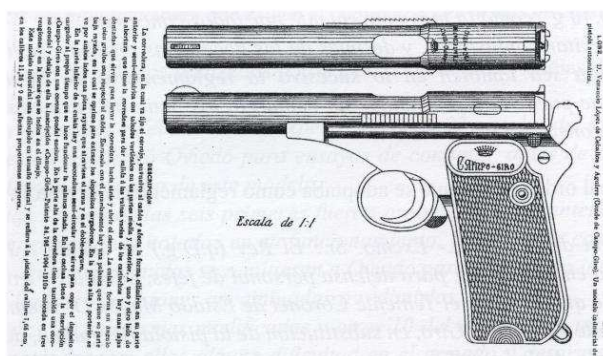

The "Campo-Giro pistol of 9 mm Model 1912" as illustrated in the "Official Bulletin of Industrial Property" where Don Venancio López de Ceballos applied for it to be registered as his property.

Two months after the Model of 1912 was approved, López de Ceballos patented a variation of his pistol with a recoil shock absorber, which meant that on January, 5, 1914, the 1912 Model was substituted for the improved model designated "Campo-Giro pistol of 9mm Model 1913"; In April of the same year of 1914, its regulation leather holster design, with compartments for a cleaning rod and an extra magazine, was approved; This gave it a capacity of 16 rounds; If a larger allotment of ammunition was felt to be necessary, two more magazines in a leather holder, could be issued.

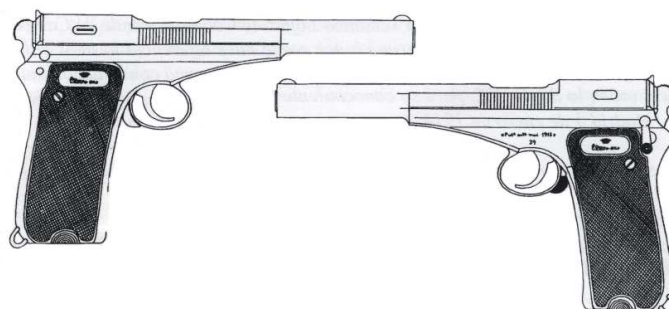

"Campo-Giro" pistol of 9 mm Model 1913; Eight round magazine in 9mm Bergmann or Campo-Giro caliber.

The Model 1912 Campo-Giro never got into production and the construction of the Model 1913 was contracted to the firm "Esperanza y Unceta" which, with its two partners Juan Esperanza and Pedro Unceta, had moved from Eibar to a new factory in Guernica, Viscaya; During 1914 a total of 1,300 units were made there after which their production was interrupted due to the need to make further improvements to the design in order to correct certain defects.

It is possible that the international demand for "Ruby type" pistols had something also to do with this interruption; At this time, with the Spanish army occupied in the pacification of Morocco, Don Antonio Vázquez de Aldana commented that "The officer who has to go out in operations and looks for a good pistol is dumbfounded

because "the Bergmann satisfies no one, the Campo-Giro is not for sale, of the 7.65 Browning he does not have the best reports "... and concludes by recommending the personal purchase of the "Parabellum" (Luger) pistol, which he considered to be superior to all the others.

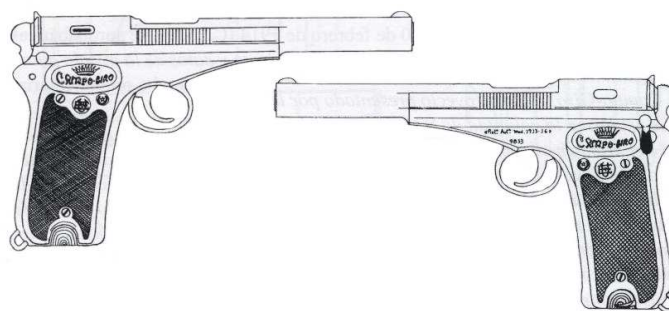

"Campo-Giro" pistol of 9 mm Model 1913-16; Eight round magazine in 9mm Bergmann or Campo-Giro caliber.

Esperanza y Unceta resumed making the Campo-Giro pistol in 1916 with a model that included all the improvements of the M1913 which Don Venancio López de Ceballos had patented in 1914 and 1915; This new model was adopted on September, 16, 1916 as the "Campo-Giro pistol of 9 mm Model 1913-16" and a total of 13,625 were made until 1919 when production ceased. That same year the issue of semi-automatic pistols had been extended to machine gunners, sappers, and demolition troops of the mixed Cavalry regiments.

THE TWO MODELS OF 1921 PISTOLS

In May of 1919 and in April of 1920, submission of competing models for field trials was requested in order to select a new model pistol for the Army but none were submitted; A third trial, in January of 1921, led to the approval of the 9mm pistol presented by the firm Esperanza y Unceta under the commercial name of ASTRA 400 and its adoption on September, 26, 1921 as the "Pistol Astra Model 1921"; A few days later, on October, 6th, its official nomenclature was changed to "9mm pistol Model 1921"; The Bergmann and Campo-Giro pistols were then declared to be "obsolescent models, but to be continued in use until the complete exhaustion of the present supplies".

In the design of this pistol, based on the Campo-Giro, Don Pedro Careaga Garagarza and Don Juan Esperanza Salvador collaborated. This was not, however, the only "Model 1921" adopted, as in September of that year the 12 gauge "Signals Pistol Model 1921" also made by Esperanza y Unceta, and sold commercially as the ASTRA 500, was also adopted.

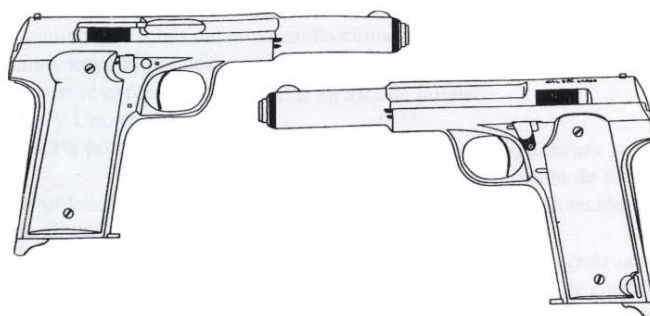

“9mm pistol Model 1921” (ASTRA 400); Eight round magazine in 9mm Largo (9mm Bergmann) caliber.

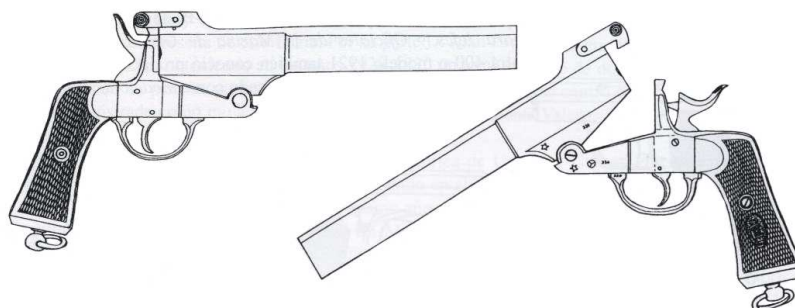

Model 1921 (ASTRA 500) signals pistol.

The “9mm pistol Model 1921” was also adopted by the Carabineros, by the Prison Corps, Navy, Military Aviation, etc; However in some of these units, like the Navy, officers opted for the 9mm Corto ASTRA 300 pistol, more comfortable to carry, and which could also be loosely, and conveniently, considered to be a “9mm pistol Model 1921” as the designation did not further specify the type of round (largo or corto) as at the time the only 9mm ASTRA service pistol was the one for the 9mm round used by the Bergmann and the Campo-Giro pistols.

In 1923 Don Juan Salvador Esperanza founded the firm “Esperanza y Cia” (ECIA) and abandoned Esperanza y Unceta which was then restructured as “Unceta y Cia” and continued the production of the “9mm pistol Model 1921” (ASTRA 400) while at the same time introducing its new model ASTRA 300, which was made in 7.65mm and 9mm Corto, which made it necessary, from that point on, to specify that the regulation cartridge was the 9mm Bergmann or “Largo”.

The Navy adopted the “9mm pistol Model 1921” on September, 24, 1923 although in a variant denominated “de Marina” (or Naval model) with a magazine release system similar to the one on the ASTRA 300, which was being marketed at the time by Unceta as “The only regulation model for Chiefs and Officers of the Navy”, in spite of the fact that the 9mm Corto was not a regulation cartridge.

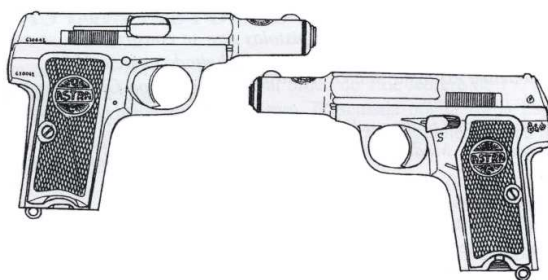

"ASTRA 300" pistol, six round magazine in 9mm Corto caliber.

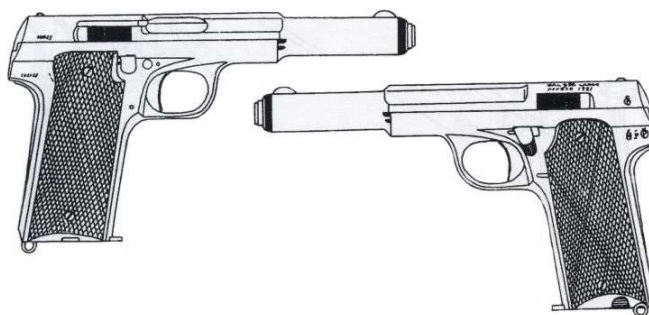

Navy "9mm pistol Model 1921"; Eight round magazine in 9mm Largo (Bergmann) caliber.

Upon the start of the Civil War in July of 1936 the Unceta y Cia factory was confiscated by the Government of Euzkadi (Autonomous Basque Government); It suffered no damage during the bombing of Guernica by the Condor Legion and, in April of 1937 passed into Nationalist control who kept it militarized until May of 1938 when Unceta y Cia recovered its property and continued production of the ASTRA 400 until 1945; The ASTRA 300 was kept in production until 1947; A total of 106,175 ASTRA 400 and 171,300 ASTRA 300 were produced.

During the Civil War (1936-39) the Catalonian Generalitat (Autonomous Catalonian Government) and the Republican Government manufactured copies of the "9mm pistol Model 1921" (the ASTRA 400) in both Catalonia and the Levant; In Catalonia it was produced as the "F.ASCASO", in honor of Francisco Ascaso, an anarchist leader who was killed at the very onset of the rebellion in Barcelona; It was made in the city of Tarrasa in workshops adapted to the construction of handguns; The Republican Government manufactured its copy in shops in the city of Alginet (Valencia) and marked them "R.E" (República Española).

About 15,000 RE models and 5,000-8,000 ASCASOs were made; A third variant, without grip safety and no markings except for a serial number was made, probably in the city of Valencia, with a very low production of only 200-300 units.

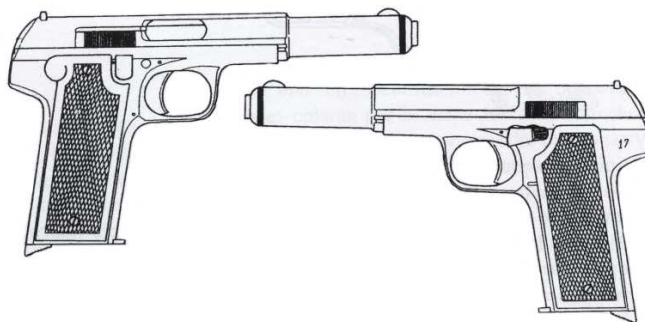

Copy of the “9mm pistol Model 1921”, variant without grip safety; Eight round magazine in 9mm Largo (Bergmann) caliber.

THE “STAR” PISTOLS, MODELS OF 1919, 1921, 1922, AND “STAR A SUPER”

Since there were no participants in the Army pistol trials of 1919 and 1920 and the Director General of the Guardia Civil felt that there was urgency in substituting their M-1884 (No.7 Smith) revolvers for semiautomatic pistols he opted to equip them with the “STAR military model of 1920” pistol manufactured in Eibar by the firm of “Bonifacio Echeverría”.

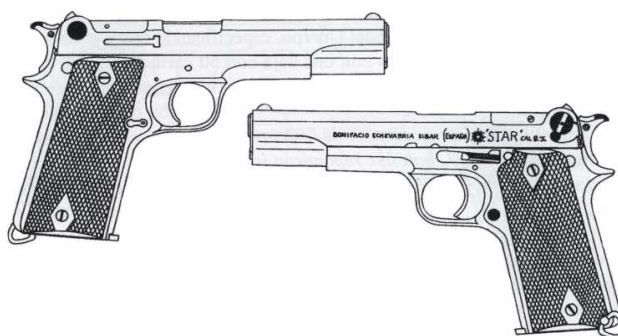

“STAR Military Model of 1920”; Eight round magazine in 9mm Largo (Bergmann) calibre; Safety on frame

On November, 4, 1920 their acquisition was authorized by the Ministry of the Interior since the Ministry of War could only approve the purchase of an officially accepted regulation model and that acceptance did not take place until September 1, 1921 when the ASTRA 400 was selected as the “9mm pistol Model 1921” Army pistol in detriment of the STAR pistol; Since by that time the Guardia Civil had already fielded a considerable number of STAR pistols it was decided to declare it regulation “for the exclusive use of all classes and individuals of the Guardia Civil” as the “9mm Largo STAR pistol” without specifying any “Model”; This was due to the fact that there were two “STAR” pistols in service by the Guardia Civil as, when Bonifacio Echeverría ended production of the

"STAR military model of 1920" he supplied specimens of the "STAR military model of 1921" with grip safety which was then followed by the "STAR military model of 1922", without the grip safety; By October of 1935 the Guardia Civil had procured a total of 31,883 9mm Largo STAR pistols.

In March of 1940 the Guardia Civil was reorganized and absorbed the Corps of Carabineros; Since the carabineros were already equipped with the (ASTRA 400) "9mm pistol Model 1921", from that point on both models, the ASTRA 400 and the STARS, jointly equipped the restructured Guardia Civil; The "military model" as manufactured at the time by Bonifacio Echeverría was the same as the commercial "STAR A" which, in addition to the Guardia Civil was also adopted by the "Ejército del Aire", the new independent Spanish Air Force (previously an Army Air Corps or Military Aviation, a branch of the Army), created by Law of October, 8, 1939.

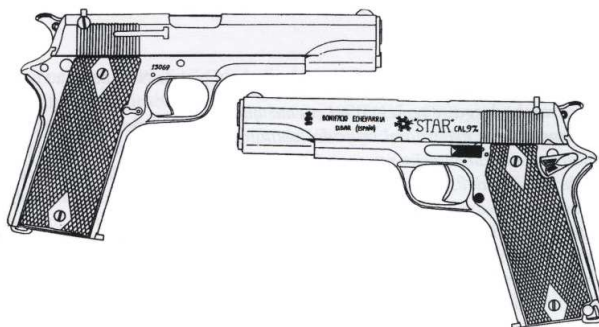

"STAR Military Model of 1921"; Eight round magazine in 9mm Largo (Bergmann) calibre; With grip safety.

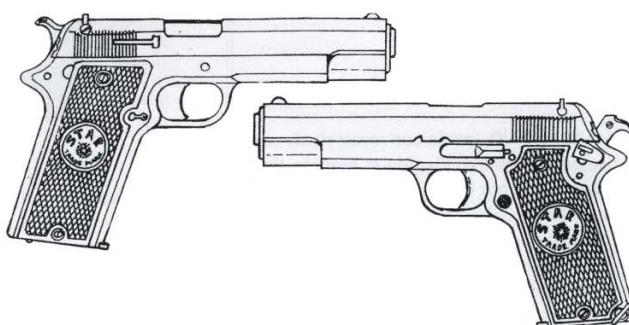

"STAR" Military Model of 1922; Eight round magazine in 9mm Largo (Bergmann) calibre; Without grip safety.

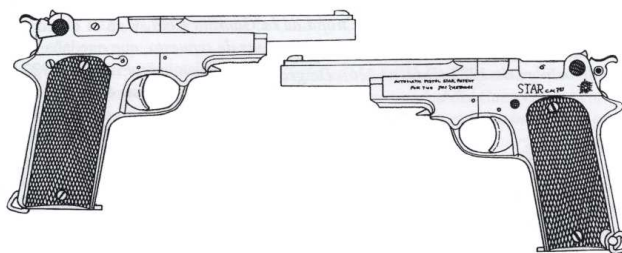

"STAR" M1919 pistol, 7.65mm caliber; Nine round magazine; Model acquired in 1920 by the Diputación de Vizcaya (provincial government of Vizcaya), for the "Cuerpo de Miñones", a security force.



"STAR A SUPER" pistol; Nine round magazine in 9mm Largo caliber.

In the mid-1940s new trials were conducted in order to select a new pistol model to substitute the Army's "9mm pistol Model 1921" and Bonifacio Echeverria's new "STAR A SUPER" model was selected and adopted by the Army (Ejército de Tierra) on July, 24, 1946 and by the Navy on October, 25 of the same year.

The "STAR A SUPER" was the last model chambered for the "regulation 9mm Largo" cartridge to be used by the Spanish Armed Forces.

THE MAUSER-TYPE, "ISARD", AND "NACIONAL" PISTOLS

In Spain the manufacture of C96 Mauser based pistols started around 1927 by the firm of "Beistegui Hermanos" and Unceta y Cia with the intention of exporting them; In 1931 after the proclamation of the Republic, the government, alleging public security reasons, created a Commission in order to confiscate all the "war" weapons and munitions which were stored in the private factories; These were then acquired by the Ministry of War, although the confiscation was limited to those with selective fire mechanism, and the exportation of the other ones (non selective fire) was authorized.

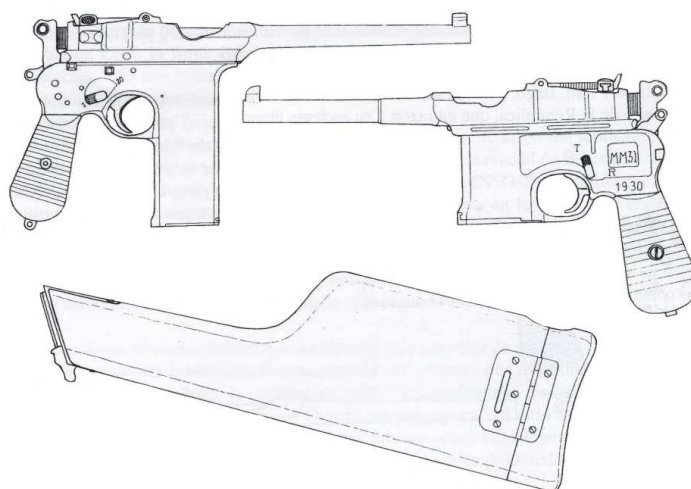

"ASTRA 902" pistol, caliber 7.63mm Mauser; Twenty round magazine, and "MM-31" pistol, caliber 7.63mm Mauser; Ten round magazine.

The Ministry of War acquired a good number of "ASTRA 901" and "ASTRA 902"s made by Unceta y Cia and of "M.M.31"s made by Beistegui Hermanos, all of them "Mauser type" in Mauser 7.63mm caliber; Since the regulation cartridge in all the services was the 9mm Largo, it was decided to issue these pistols to a newly created public security force, the "Guardias de Asalto de la República".

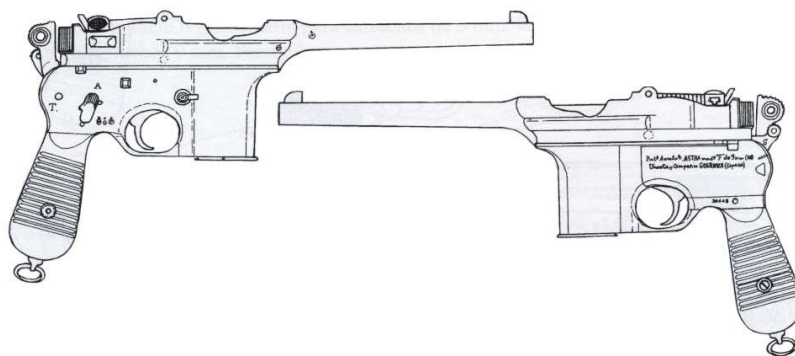

"ASTRA F" pistol, caliber 9mm Largo; Ten and twenty round magazines.

After the 1934 revolution in Asturias it was decided to equip the Guardia Civil with selective fire capable pistols and trials were held to select a model, which had to be, in the regulation 9mm Largo caliber, and with a mechanism designed to control its burst cyclic cadence or rate of fire in order to make them more controllable.

Beistegui Hermanos presented their "MM 34" pistol and Unceta y Cia, its "ASTRA F" which was selected by the Guardia Civil and 1,000 units were ordered with, five twenty round, and one ten round, magazines each.

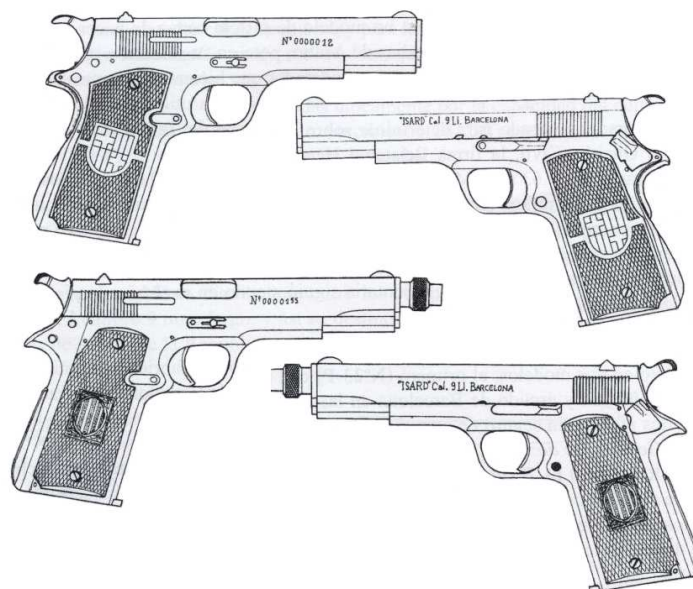

"ISARD" pistols, first and second type; Eight round magazines in 9mm Largo caliber.

The "ISARD" pistols were made in Barcelona during the Civil war in the "Talleres del Parque Móvil de la Generalitat" (workshops of the automobile depots of the Autonomous Government); They were weapons for the 9mm Largo cartridge, inspired by the Colt M1911, and produced in a minimal quantity, about 200 units, including two models mainly differentiated by having a one or two piece frame.

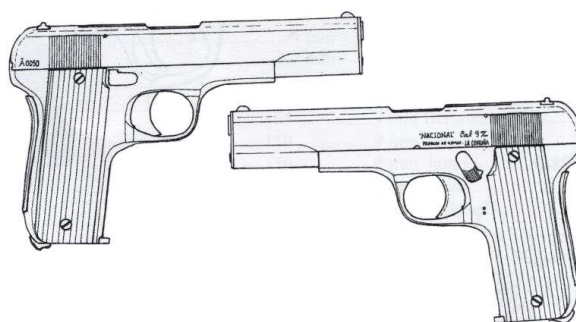

"NACIONAL" pistol, in 9mm Largo caliber; Eight round magazine.

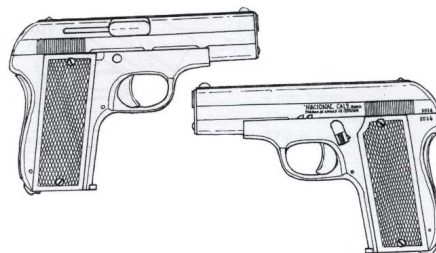

"NACIONAL" pistol, in 9mm Corto caliber; Seven round magazine.

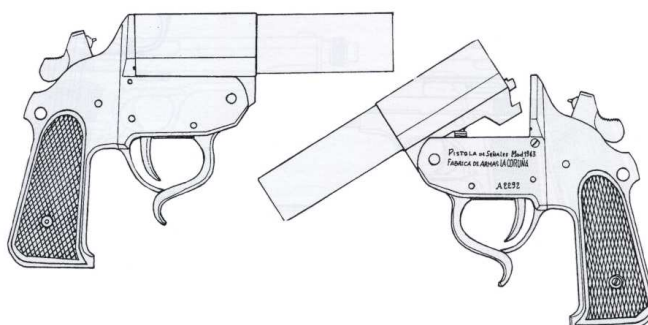

Model 1943 Signals pistol

During the Civil War the Nationalists organized portable firearms (handguns and rifles) manufacture at La Coruña (in Galicia in North West Spain) and established there a factory which, once the war was over was added to the State owned factories; In a project there to develop pistols for the Armed Forces the “NACIONAL” pistols were designed in two models, for 9mm Largo and 9mm Corto respectively; These guns were made in 1941 in a very limited quantity of 50 units, which upon the project being abandoned, were destroyed.

With somewhat better luck the “27 mm Model 1943 Signals Pistol” was produced there and adopted that year by the Army to succeed the “ASTRA 500” that had been adopted in 1921.

August, 2010